

# ANALOGUE GAUGING & MEASURING SOLUTIONS

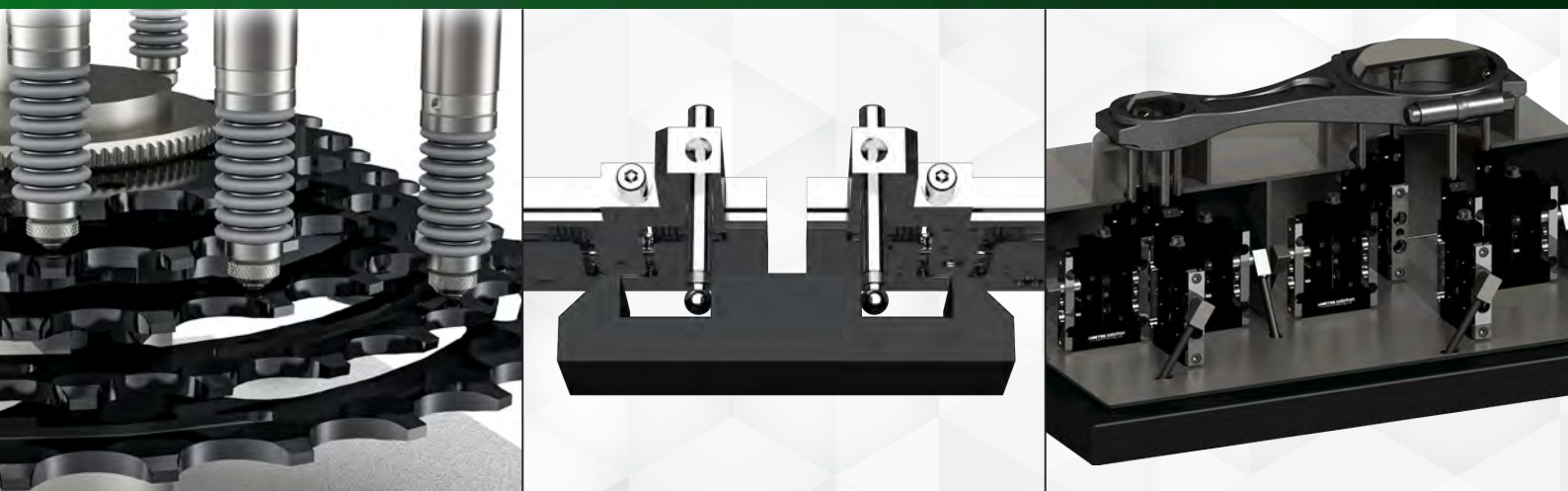

VAST RANGE OF PROBES TO  
SUIT ALL APPLICATIONS

“Working with our customers and partners to provide complete precision linear measurement solutions”

“配合客户和合作伙伴提供完整的精密线性测量解决方案”

“Travailler avec nos clients et partenaires pour fournir des solutions de mesures linéaires précises et complètes”

“Zusammenarbeit mit Kunden und Partnern für die Bereitstellung präziser Messlösungen”

“Lavoriamo con i nostri clienti e partner per fornire soluzioni di misura lineare complete ed accurate”

“お客様へ高精度のリニア測定を実現するためのソリューションを提供します。”

“Trabalhando com nossos clientes e parceiros para fornecer soluções precisas em medição linear”

“Сотрудничество с клиентами и партнерами обеспечивает наилучшие комплексные решения в области высокоточных систем линейных измерений”

“Trabajamos con nuestros clientes y socios para proporcionarles soluciones completas en medidas lineares de precisión”

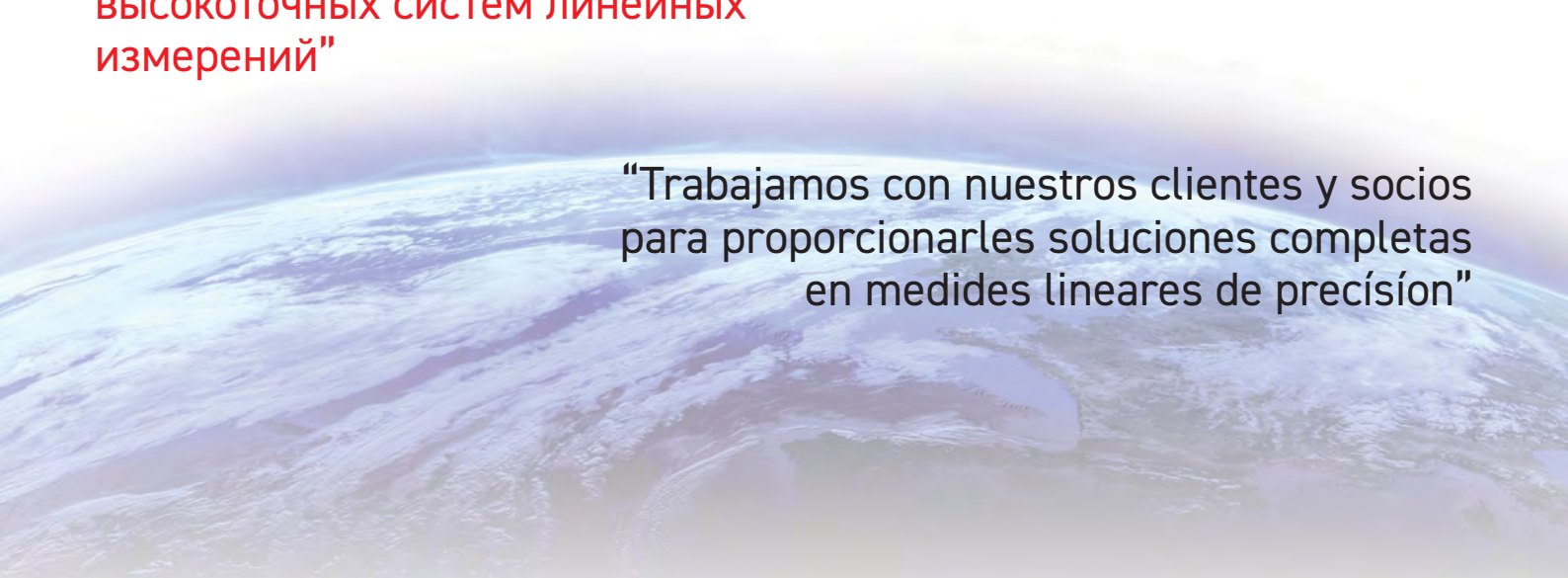

# CONTENTS



**Solartron Metrology Overview**  
Page 4 - 5



**Applications**  
Page 6 - 7



**Inductive Technology**  
Page 8 - 9



**Spring, Pneumatic & Vacuum Probes**  
Page 11



**Low Tip Force Probes & Probes with Integrated Electronics**  
Page 12 - 13

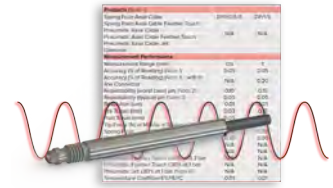

**Analogue Probe Specifications**  
Page 14 - 15



**Block & Flexure Gauges**  
Page 16 - 17



**Block & Flexure Specifications**  
Page 18 - 19



**Mini Probe & Specifications**  
Page 20 - 21



**Conditioning Electronics & Specification**  
Page 22 - 25



**SI3100 Readout & Accessories**  
Page 26 - 27

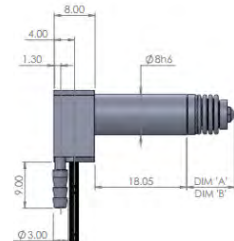

**Dimensions**  
Page 28 - 31

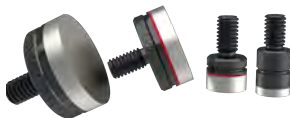

**Probe Tips**  
Page 32 - 33



**The Orbit® Digital Network**  
Page 34 - 35



**Orbit® Products**  
Page 36 - 37



# SOLARTRON METROLOGY OVERVIEW

## ABOUT US

Solartron Metrology is a world leader in the design and manufacture of precision dimensional gauging probes and associated instrumentation. Established in 1946 and headquartered in the UK, Solartron has a large global network of Sales offices and highly technical distributors ensuring worldwide support. All of our products are manufactured in the UK.

In the laboratory or on the shop floor Solartron's products provide accurate linear measurements for quality control, test and measurement and machine control in a variety of industries, such as automotive, aerospace, electronics, optics, medical and other applications, where accuracy and repeatability are critical to the process.



Solartron offers the widest range of linear measurement sensors including pencil probes and specialist sensors. **The flagship products are the Contact and Non Contact Digital Measurement Transducers which coupled with our Orbit® Digital Measuring Network provide the end user or integrator with a fast and flexible system easily configured to solve your measurement problem.**

Solartron Digital Orbit® probes are not considered a cost, but an investment. With calibration, ease of setup and durability, the Orbit® system provides immediate cost savings for any quality system.

Many of the more precise or smaller sensors are only available in digital format operating with Orbit® Digital Measuring Network. See Page 34 for more on Orbit®.

## THE ANALOGUE PRODUCT FAMILY

Solartron Metrology's analogue gauging probes and special sensors use an inductive sensor to measure the position of the probe tip. The sensors are available in both LVDT (linear variable differential transformer or half bridge configuration).

Solartron also provide a range of conditioning electronics that allow the user to interface to the probes. Solartron have a vast range of probes to suit all applications.

## GAUGING PROBES (PENCIL PROBES)

Solartron Metrology contact gauging probes, LVDT probes or displacement sensors provide the gauge builder with the most cost effective solution for a range of dimensional precision measurement and positioning applications.

In a conventional LVDT sensor the displacement probe tip is pushed out using an internal spring. The precision bearings inside the linear displacement sensor ensure precise positioning of the gauge probe tip.

Attention to detail in both design and manufacture of the displacement sensor ensures precision measurement throughout the linear displacement transducer's life.



# SOLARTRON METROLOGY OVERVIEW

## SPECIALIST TRANSDUCERS

Solartron's specialist gauging and measurement transducers are for applications where the standard pencil style probe will not fit. Ranging durability to versatility, and a combination of the two, these specialist transducers can be applied to a multitude of measurement challenges.



## ORBIT® DIGITAL MEASUREMENT NETWORK

Orbit® provides a complete solution for integrating different measurement position and control sensors smoothly and simply into network solutions. Refer to page 34 for details.



## POSITION CONTROL AND DISPLACEMENT MEASUREMENT

Alongside our highly successful range of Digital Transducers for precise measurement of parts in manufacturing we also offer a range of displacement sensors for position control in industry, the laboratory and test environments

Nearly all of these sensors can be integrated with the flexible Orbit® Measurement Network or provided with integral voltage or current outputs.

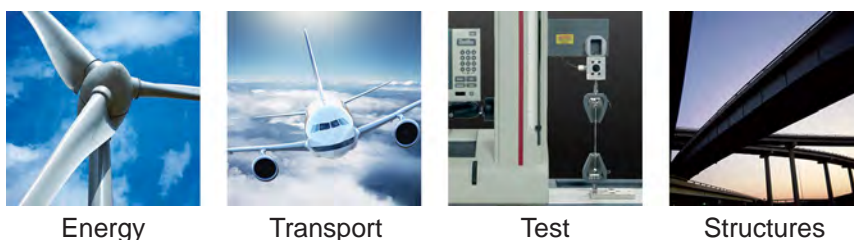

Energy

Transport

Test

Structures

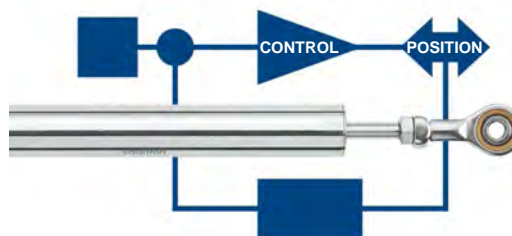

## CUSTOM PRODUCTS

**A special kind of service.**

At Solartron Metrology our vastly experienced design team has for many years worked closely with customers to produce successful and cost effective measurement solutions. If you have a seemingly intractable linear measurement problem please contact our Sales Team.



# APPLICATIONS

## ANGLES AND FLATNESS

The precision measurement of angles requires high resolution + excellent linearity and repeatability.

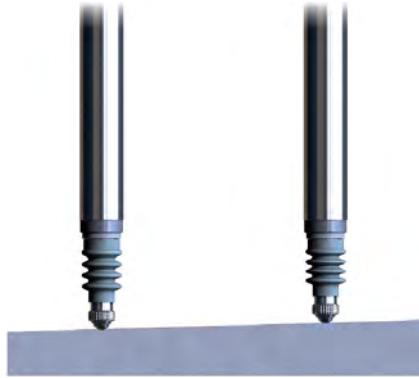

## AUTOMATIC GAUGING

Automatic gauging on-line or post-process is made possible with pneumatic probes and mechanical Interfaces.



## MEASURE OUTER DIAMETER

Use two probes to measure rotating part. Probes can easily withstand the side load.

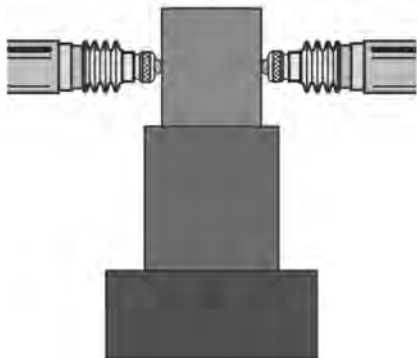

## SCARED OF DAMAGING THE PART?

The low tip force options of contact transducers can solve your problems.



## MEASURE TIR

Max – Min. Special tips can also be used.



## BEARING INDUSTRY

The grading of bearing components are among the most demanding of all post process gauging applications. Both Flexures and Block Gauges provide fast and reliable measurements in hard to reach places.

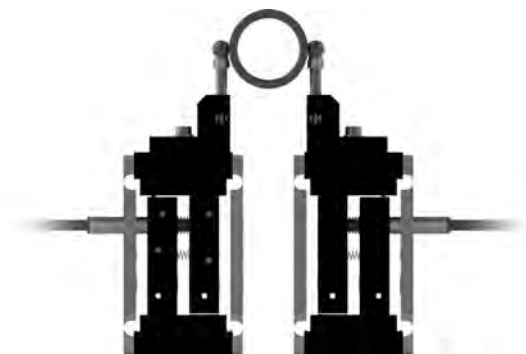

# APPLICATIONS

## CHECK HEIGHT OF SEMI-CONDUCTOR WAFER

The precision measurement of angles requires high resolution + excellent linearity and repeatability.

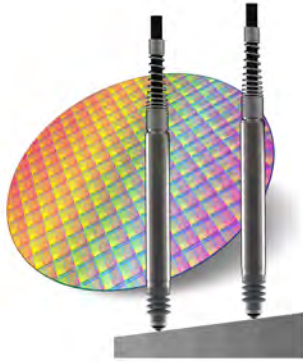

## PROCESS MONITORING

Use Probes to monitor distances traveled, such as the distance a screw is inserted into a metal sheet.

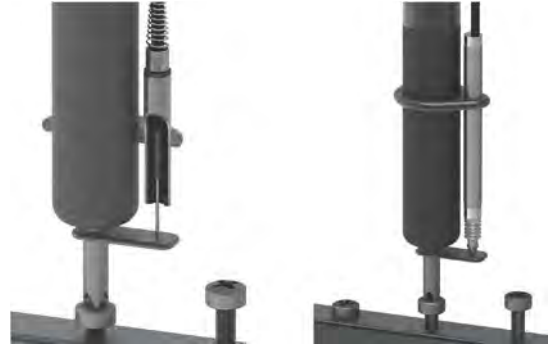

## Measure Inner Diameter

Analogue Mini Probes (half bridge only) can be used for bore gauging.



## PROBE WITH SIGNAL CONDITIONER

For simple single channel checks, G-Type can be configured for VDC or 4-20 mA output.

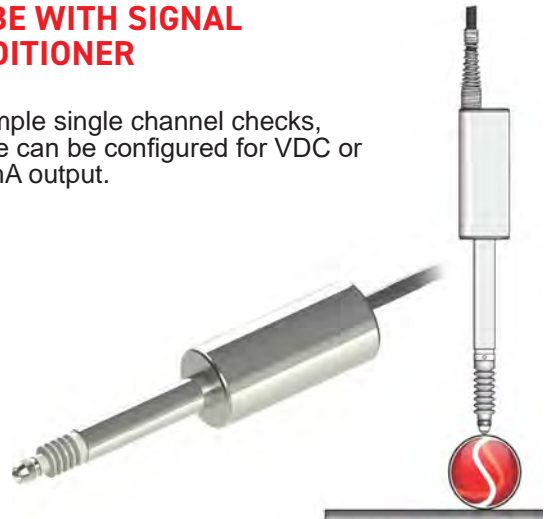

## SMALL SPACE

Use 6 mm diameter probes for small areas where multiple points must be checked.

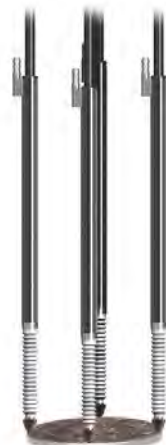

## CHECK GEOMETRIC SHAPES

Excellent repeatability means gauging probes can be min/max mastered and provide accurate results time and again.





# INDUCTIVE TECHNOLOGY

## PRINCIPLE & OPERATION

An LVDT (linear variable differential transformer) inductive displacement sensor is constructed using a static transformer primary winding and two secondary windings. The windings are formed on a hollow bobbin through which a magnetic core can travel. The core provides a path for linking the magnetic flux generated in the primary coil, when this is energised with an AC signal, to the secondary coils. The position of the core in the bobbin controls how much flux is coupled to each of the secondary coils.

The secondary coils A and B are connected in series opposition so that the two voltages  $V_A$  and  $V_B$  have opposite phase and the transducer output is  $V_A - V_B$ . If the core is in the central position then voltages of equal magnitude, but opposite phase are induced in each secondary and the resulting output is zero. When the core is moved in one direction, the voltage in one secondary increases and that in the other decreases. The net effect is an output that is proportional to the position of the core.

Knowledge of the magnitude and phase of the output with respect to the excitation signal allows one to deduce the position of the core with respect to the zero position.

The output of an LVDT is a linear function of the displacement over its calibrated range. Beyond this range the output becomes increasingly non linear. Measurement range is defined as  $\pm$  distance from the transducer zero or null position.

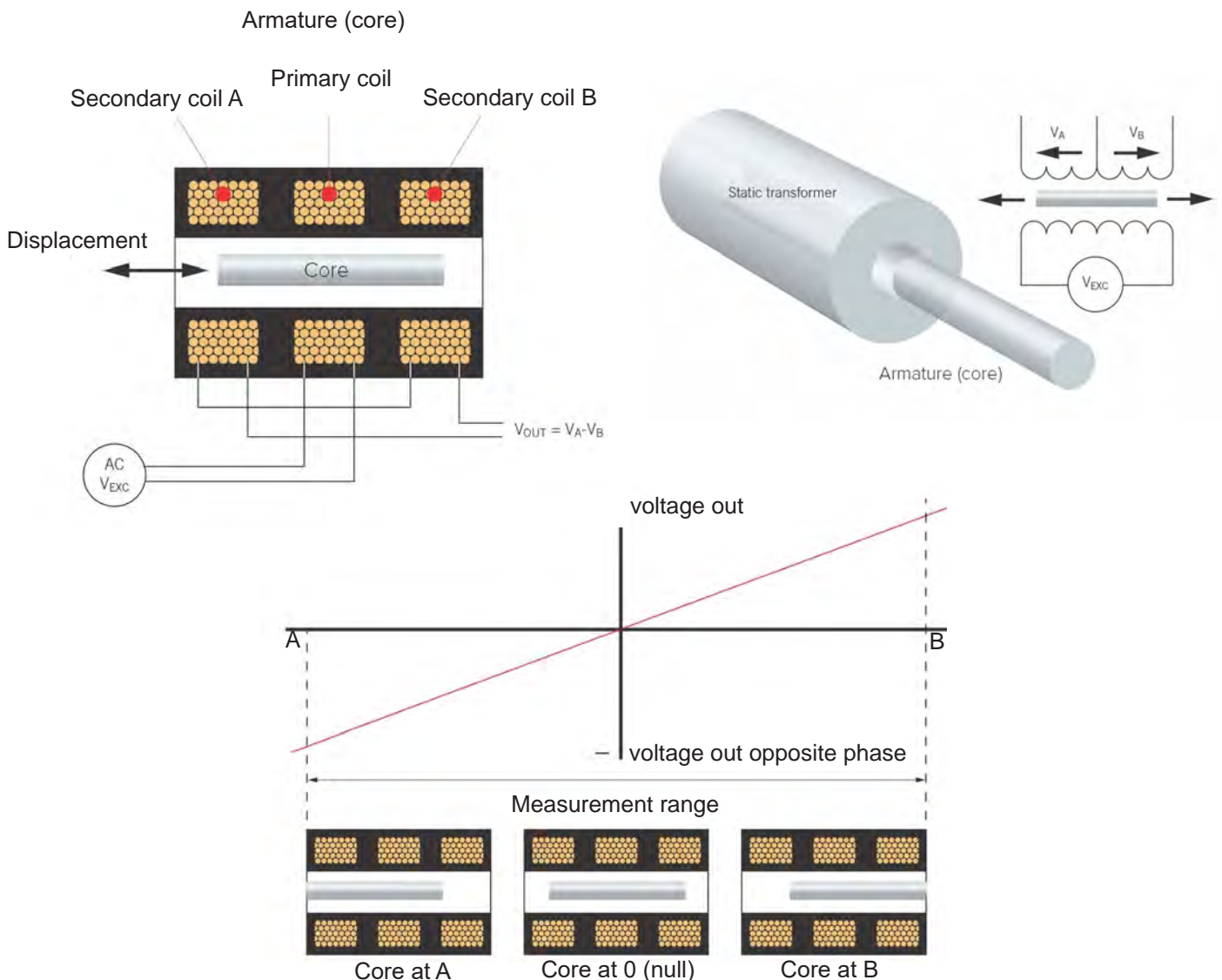



# INDUCTIVE TECHNOLOGY

## LVDT AND HALF BRIDGE

An LVDT and a Half Bridge are two alternative approaches to the coil format and are described in this section.



## CONVENTIONAL HALF BRIDGE

The half bridge transducer forms half of a Wheatstone bridge circuit, which enables change from null to be easily detected. The other half of the bridge is contained within the conditioning electronics. When the core is in the null position the bridge is balanced and the output is zero. As the core moves the relative inductance of the bridge changes producing an output.

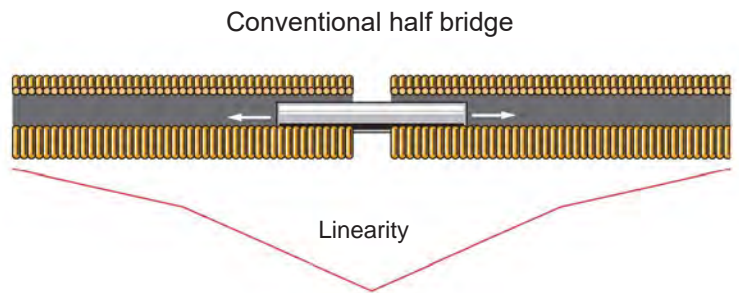

## CONVENTIONAL LVDT

If the core is in the central position then voltages of equal magnitude, but opposite phase are induced in each secondary and the resulting output is zero. When the core is moved in one direction, the voltage in one secondary increases and that in the other decreases. The net effect is an output that is proportional to the position of the core.

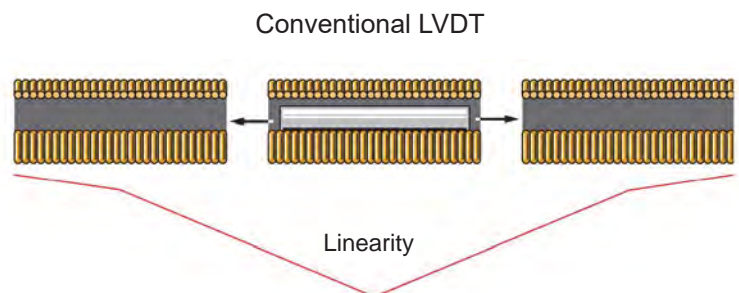

## SOLARTRON HALF BRIDGE AND LVDT

Solartron has continually developed precision bobbin mouldings including multi chamber bobbins which in conjunction with skilled design of the coils ensure excellent stability and linearity.

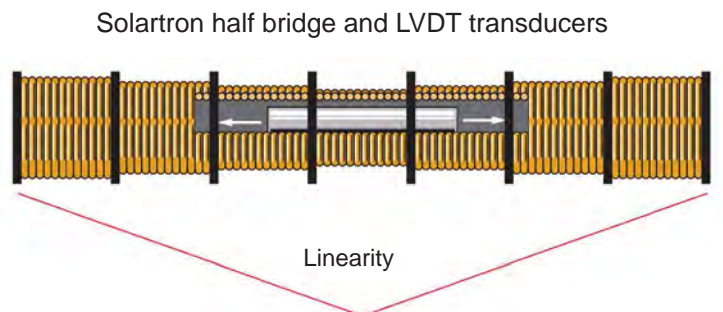

Solartron can also provide inductive transducers designed to match those of other supplier standards, such as Tesa, Mahr, Marposs etc.

# ROBUST DESIGN - THE FINEST QUALITY

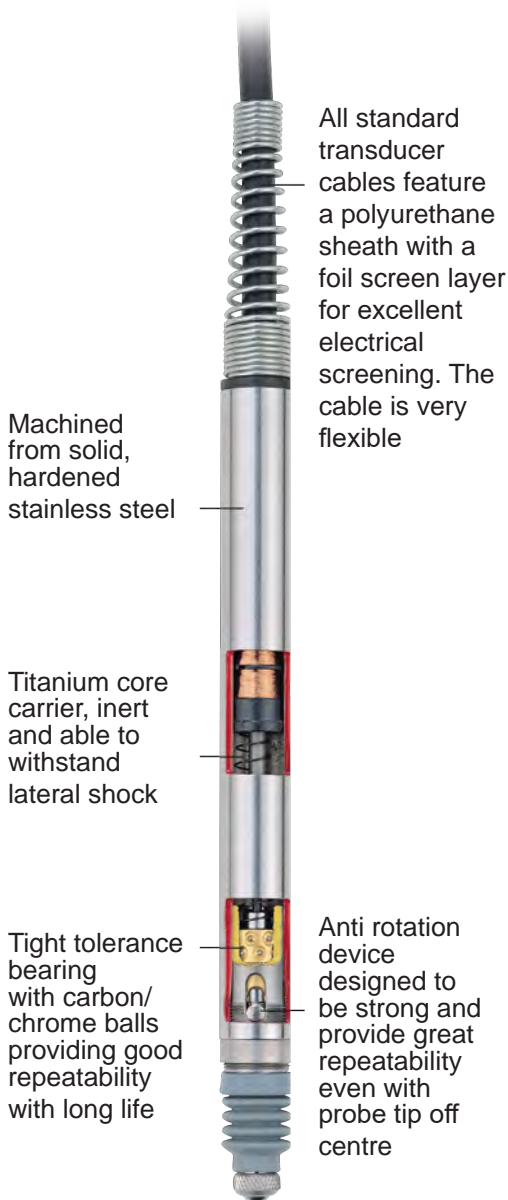

**Contact gauge Probes very often provide the only cost effective solution for a wide range of measuring and positioning applications in diverse industries.**

As with all mechanical transducers, life is of paramount importance. It is not too difficult to produce a gauge probe that works well when new, but considerably more difficult to produce a probe that maintains its performance throughout a long working life.

It requires close attention to detail in design and manufacture as well as investment in state of the art machines to produce precision bearings which are the heart of a gauge probe.

Solartron Metrology has complete control over all aspects of the design and manufacture of its sensors. Whether the application is in the laboratory or in manufacturing our extensive range of transducers will most likely provide a solution. If nothing seems to meet your need we will always consider **customised** products.

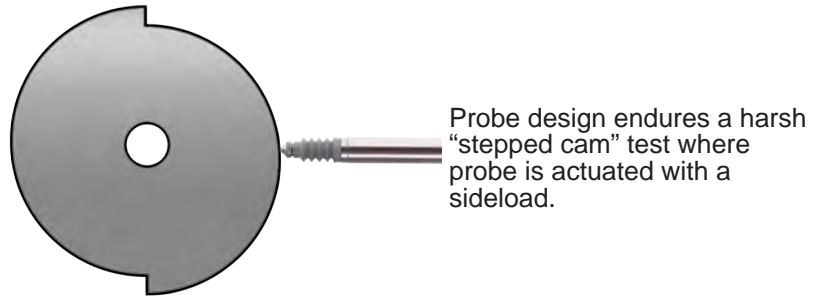

Probe design endures a harsh "stepped cam" test where probe is actuated with a side load.

## OUTPUT OPTIONS

The measuring principle is either LVDT or Half Bridge. Probes can be supplied with outputs configured to match all major compatibles including, Mahr, Mahr-Federal, Tesa and Marposs.

ELECTRICAL SPECIFICATIONS OF VARIOUS COMPATIBILITIES			
	Carrier Frequency KHz	Sensitivity	Amplitude
Mahr	19.4	192.00	5.0
Mahr-Federal	5.0	78.74	2.0
Tesa	13.0	73.75	3.0
Marposs	7.5	230.00	3.5

# SPRING, PNEUMATIC AND VACUUM PROBES

Contact gauge probes often provide the most cost effective solution for a wide range of measuring and positioning applications.

In a conventional pencil probe the tip is pushed out using an internal spring. When installed in a fixture it is frequently required to design a mechanism to bring the probe into contact with the part being measured.

A pneumatic probe (either pneumatic push or vacuum retract) allows the number of parts in the fixture to be reduced resulting in improved reliability and reduced fixture cost. It also allows for fast automatic loading of the part into the gauge as the probe tip can be in the fully 'retract position' when this is occurring. Probes such as the AX/5/1 have a mechanical movement of 10 mm with a calibrated range of  $\pm 1$  mm at the beginning of the movement.



## AX/S - SPRING PUSH

- ▶  $\pm 0.25, \pm 0.5, \pm 1, \pm 1.5, \pm 2.5, \pm 5$  &  $\pm 10$  mm Measuring ranges
- ▶ Accuracy as low as  $1 \mu\text{m}$
- ▶ Up to  $0.05 \mu\text{m}$  measurement repeatability
- ▶ Tip force 0.7 N (options available)
- ▶ IP65 sealing
- ▶ Spring actuation



AX/0.25/S Probe



## AX/P - PNEUMATIC PUSH

- ▶  $\pm 1, \pm 2.5, \pm 5$  &  $\pm 10$  mm measuring ranges
- ▶ Accuracy as low as  $1 \mu\text{m}$
- ▶ Up to  $0.05 \mu\text{m}$  measurement repeatability
- ▶ Tip force 0.7N (options available)
- ▶ IP65 sealing
- ▶ Pneumatic gaiter actuation
- ▶ Vacuum retract options also available

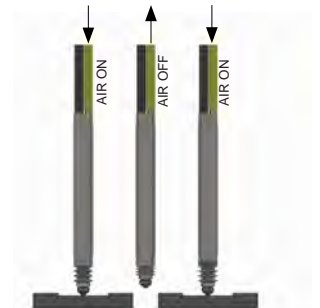

## AJ/P - JET PNEUMATIC PUSH

- ▶  $\pm 1, \pm 2.5, \pm 5$  &  $\pm 10$  mm measuring ranges
- ▶ Same performance as standard pneumatic probes
- ▶ Pneumatic actuation using built in piston – separate from gaiter
- ▶ IP50 sealing

With conventional pneumatic transducers, the air pressure is contained within the gaiter. The Jet range pneumatic transducers are designed so that the gaiter is not pressurised. This has the advantage that gaiter damage will not affect operation resulting in less downtime and reduced cost of ownership.



APPLICATION: DIAMETER CHECK



APPLICATION: FLATNESS

# LOW TIP FORCE PROBES

Feather Touch Probes have been designed to gauge delicate surfaces, such as glass, thin sections, pharmaceutical products and tiny electro mechanical components.

Whereas the traditional gauging probe exerts a force of 0.7N, the Feather Touch probe when operated horizontally exerts a mere 0.18 N.

This is achieved by replacing the naturally elastic gaiter with a close tolerance gland. On pneumatic versions air leakage through this gland is less than

2.5 ml per second at 1 bar pressure, avoiding surface contamination while still providing a degree of cleaning the probe bearing.



## AT - FEATHER TOUCH

- ▶  $\pm 1, \pm 1.5, \pm 2.5, \pm 5$  &  $\pm 10$  mm measuring ranges
- ▶ Accuracy as low as  $1 \mu\text{m}$
- ▶ Up to  $0.05 \mu\text{m}$  measurement repeatability
- ▶ Tip force 0.18 N (options available)
- ▶ IP50 Sealing
- ▶ Spring actuation



## AW - ULTRA LOW TIP FORCE

- ▶  $\pm 5$  mm measuring ranges
- ▶ Accuracy as low as  $1 \mu\text{m}$
- ▶ Up to  $0.05 \mu\text{m}$  measurement repeatability
- ▶ Tip force as low as 0.03 N
- ▶ IP50 Sealing
- ▶ Spring and pneumatic actuation

The Ultra Feather Touch probe has so light a tip force, it is a viable alternative to a non-contact sensor in many applications. With various tips available in ruby and nylon, the UFT is already being used to check glass, rubber, semi-conductor wafers and other delicate materials.



Application: Glass Thickness

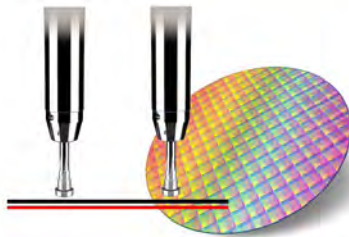

Application: Semi Conductor Wafer



Application: Hard Disk Drive Case



## A6G - SMALL DIAMETER PROBES (06 MM)

- ▶  $\pm 1$  measuring ranges
- ▶ Accuracy as low as  $1 \mu\text{m}$
- ▶ Up to  $0.05 \mu\text{m}$  measurement repeatability
- ▶ Tip force 0.7 N
- ▶ IP65 Sealing
- ▶ Spring and pneumatic actuation

The A6G range of probes are only 6 mm diameter, but still incorporate a precision linear bearing, this allows probes to be closely packed together for accurate measurement of close features. For Pneumatic specifications please contact your local Solartron representative.



# PROBES WITH INTEGRATED / INLINE ELECTRONICS



## G SERIES SPRING PUSH

- ▶  $\pm 1, \pm 2.5, \pm 5, \pm 10$  measuring ranges
- ▶ 8 mm probe body with 19 mm electronics casing
- ▶ Voltage, Current outputs
- ▶ Linearity 0.2% FSO

The G-Type of analogue DC/DC displacement probes are based on the LVDT sensing principle and features a high accuracy and long life linear ball bearing (as AX-Series). All models incorporate a Linear Variable Differential Transducer (LVDT) as the measuring element, together with high performance conditioning electronics for low noise and superior linearity while being able to cope with a wide input supply range with no change in output.

PRODUCTS				
Voltage Output (DC Bipolar)	WG/2/S/a	WG/5/S/a	WG/10/S/a	WG/20/S/a
Voltage Output (DC Unipolar)	VG/2/S/b	VG/5/S/b	VG/10/S/b	VG/20/S/b
Current Output	IG/2/S/c	IG/5/S/c	IG/10/S/c	IG/20/S/c
MEASUREMENT				
Measurement Range (mm)	2 ( $\pm 1$ )	5 ( $\pm 2.5$ )	10 ( $\pm 5$ )	20 ( $\pm 10$ )
Linearity (%FSO) / Repeatability $\mu\text{m}$	0.2 / 0.15			
Pre travel / Post Travel (mm)	0.15 / 0.85			
MECHANICAL				
Body Diameter (mm)	8 mm for shaft 19 mm for electronics housing - see page 29			
Material	Case 400 Stainless, Fluoroelastomer or Silicon Gaiters			
Tips	Same range as AX series - page 32			
Cable	PUR Std length 3 m			
ENVIRONMENTAL				
Operating / Storage Temperature $^{\circ}\text{C}$	+5 to +65 / -20 to +85			
Sealing	IP65			
ELECTRICAL INTERFACE (4-20 mA & DC)				
Input	10 to 30 V @ 30 mA (Type) or 4-20 mA loop powered			

OUTPUT OPTIONS			
	a	b	c
<b>A</b>			4-20 mA
<b>B</b>			20-4 mA
<b>C</b>			0-20 mA
<b>D</b>			20-0 mA
<b>E</b>		0-5	
<b>F</b>		5-0	
<b>G</b>		0-10	
<b>H</b>		10-0	
<b>J</b>	-5 to +5		
<b>K</b>	+5 to -5		
<b>L</b>	-10 to +10		
<b>M</b>	+10 to -10		

e.g. A) WG/2/5 with -5 to +5 output = WG/2/5/J



## PROBES WITH BICM (BOXED INLINE CONDITIONING MODULE)

- ▶ DC signal conditioner mounted on inline cable
- ▶ +/- 15 V or 24 V DC input
- ▶ +/- 5 V, +/- 10 V output signal or 0-5, 0-10 V
- ▶ IP67 casing available
- ▶ For Specs on BICM see [page 25](#)

Analogue probes can be ordered with an In-line Conditioning Module that is calibrated at the Solartron factory, providing ease of setup.



# TECHNICAL SPECIFICATIONS

Products (Note 1)		Standard, Spring, Pneumatic and Feather Touch			
Spring Push Axial Cable		N/A	AX/0.5/S	AX/1/S	AX/1.5/S
Spring Push Radial Cable		AX/0.25/S	AXR/0.5/S	AXR/1/S	AXR/1.5/S
Spring Push Axial Cable Feather Touch		N/A	N/A	AT/1/S	AT/1.5/S
Spring Push Radial Cable Feather Touch		N/A	N/A	ATR/1/S	ATR/1.5/S
Pneumatic Axial Cable		N/A	N/A	AX/1/P	AX/1.5/P
Pneumatic Radial Cable		N/A	N/A	AXR/1/P	AXR/1.5/P
Pneumatic Axial Cable Feather Touch		N/A	N/A	AT/1/P	AT/1.5/P
Pneumatic Radial Cable Feather Touch		N/A	N/A	ATR/1/P	ATR/1.5/P
Pneumatic Axial Cable Jet		N/A	N/A	AJ/1/P	AJ/1.5/P
Pneumatic Radial Cable Jet		N/A	N/A	AJR/1/P	AJR/1.5/P
Measurement Performance					
Measurement Range (mm)		±0.25	±0.5	±1	±1.5
Linearity (% of Reading)	(Note 2)	0.50	0.50	0.50	0.50
Linearity (µm)	(Note 2)	0.25	0.5	1	1.5
Maximum Repeatability (µm)	(Note 3)	0.10	0.10	0.15	0.15
Typical Repeatability (µm)	(Note 4)	0.05	0.05	0.05	0.05
Resolution (µm)	(Note 5)				
Pre Travel (mm)	(Note 6)	0.03	0.03	0.15	0.15
Post Travel (mm)	(Note 7)	0.05	0.05	0.85	0.85
Pre Travel adjustment range (mm) (Spring Push Only)		None	0.50	1.00	1.50
Tip Force (N)	(Note 8)				
Spring Push ±20 %		0.70	0.70	0.70	0.70
Spring Push Feather Touch ±20 %		0.30	0.30	0.30	0.30
Pneumatic ±20 % at 0.4 bar		N/A	N/A	0.70	0.70
Pneumatic ±20 % at 1 bar		N/A	N/A	2.60	2.60
Pneumatic Feather Touch ±30 % at 0.4 bar		N/A	N/A	0.18	0.18
Pneumatic Feather Touch ±30 % at 1 bar		N/A	N/A	1.10	1.10
Ultra Feather Touch at 0.4 bar		N/A	N/A	N/A	N/A
Pneumatic Jet ±30 % at 1 bar		N/A	N/A	0.85	0.85
Temperature Coefficient %FS/°C		0.01	0.01	0.01	0.01
Electrical Interface (Note 9)					
LVDT Sensitivity - Plugged ±0.5% (mV/V/mm)		200	200	200	133
LVDT Sensitivity - Unplugged ±5% (mV/V/mm)		262	262	215	150
Half Bridge Sensitivity - Plugged ±0.5% (mV/V/mm)		73.5	73.5	73.5	49
Half Bridge Sensitivity - Unplugged ±5% (mV/V/mm)		82	82	83	82
LVDT Energising Current ±5% (mA/V)		2.2	2.2	1.8	2
Half Bridge Energising Current ±5% (mA/V)		1.2	1.2	1	1
Environmental					
Sealing for Probe					
Storage Temperature (°C)					
Operating Temperature (°C)					
Probe Life					Up to 100 million
Materials					
Probe Body					
Probe Tip Options					
Gaiter					
Cable					Standard 2 m length, Standard cable has PUR sheath, nylon braided,

- ▶ Note 1: Product descriptions shown are for LVDT probes. For Half Bridge add H to the end e.g. AX/1/SH. All performance parameters identical except sensitivity
- ▶ Note 2: Accuracy is either µm or % reading, whichever is greater
- ▶ Note 3: Repeated operation against a carbide target with side load applied to the tip, max - min result
- ▶ Note 4: Repeated operation against a carbide tip standard deviation from average (68%)
- ▶ Note 5: Resolution depends on the conditioning electronics used

# TECHNICAL SPECIFICATIONS

AX/2.5/S	AX/5/S	AX/10/S	AX/5/1/S	AW/5/S	A6G/1/S
AXR/2.5/S	AXR/5/S	AXR/10/S	AXR/5/1/S	N/A	N/A
AT/2.5/S	AT/5/S	AT/10/S	AT/5/1/S	N/A	N/A
ATR/2.5/S	ATR/5/S	ATR/10/S	ATR/5/1/S	N/A	N/A
AX/2.5/P	AX/5/P	AX/10/P	AX/5/1/P	AW5/P	N/A
AXR/2.5/P	AXR/5/P	AXR/10/P	AXR/5/1/P	N/A	N/A
AT/2.5/P	AT/5/P	AT/10/P	AT/5/1/P	N/A	N/A
ATR/2.5/P	ATR/5/P	ATR/10/P	ATR/5/1/P	N/A	N/A
AJ/2.5/P	AJ/5/P	AJ/10/P	AJ/5/1/P	N/A	A6J/1/P
AJR/2.5/P	AJR/5/P	AJR/10/P	AJR/5/1/P	N/A	N/A
±2.5	±5	±10	±1	±5	±1
0.50	0.50	0.70	0.50	0.50	0.50
2.5	5	10	5	5	1
0.15	0.15	0.15	0.15	0.15	0.15
0.05	0.07	0.10	0.05	0.07	0.05
0.15	0.15	0.15	0.15	0.15	0.15
0.85	0.85	0.85	8.85	0.85	0.35
1.50	1.50	None	None	None	None
0.70	0.70	0.70	0.70	N/A	0.70
0.30	0.30	0.30	0.30	0.03-0.06	N/A
0.70	0.70	0.70	N/A	N/A	0.70
2.60	2.60	2.60	N/A	N/A	N/A
0.18	0.18	0.18	N/A	N/A	N/A
1.10	1.10	1.10	N/A	N/A	N/A
N/A	N/A	N/A	N/A	0.03-0.06	N/A
0.85	0.85	0.85	N/A	N/A	1.0
0.01	0.01	0.01	0.01	0.01	0.02
80	40	20	200	40	200
150	105	33	20	105	269
29.4	14.7	7.35	73.5	14.4	73.5
82	51	33	83	51	88
2	2	1	1.8	2	3
1	1.2	1.2	1	1.2	1.2
IP65 with gaiter or IP50 without gaiter					
-20 to +80					
+5 to +80 with gaiter or -10 to +80 without gaiter					
cycles depending on application, typical 10 million in most applications					
Stainless Steel					
Nylon, Ruby, Silicon Nitride, Tungsten Carbide					
Fluoroelastomer or Silicon					
steel braided or armoured options available					

- ▶ Note 6: Distance from the fully out position to start of calibrated measuring range
- ▶ Note 7: Distance from the end of the calibrated measuring range to the fully in position
- ▶ Note 8: Tip force is at the mid point of the measuring range
- ▶ Note 9: LVDT probes are calibrated at 3 V, 5 kHz into a 10 kΩ load (100 kΩ unplugged). Half Bridge at 3 V, 10 kHz into a 2 kΩ load (1 kΩ unplugged). The probes will operate at energising voltages between 1 and 10 V and frequencies between 2 and 20 kHz, but the performance is not specified

# SPECIALIST TRANSDUCERS

Solartron's specialist gauging and measurement transducers are for applications where the standard pencil style probe will not fit.



## BG - Block Gauge

- ▶  $\pm 1$ ,  $\pm 2.5$  &  $\pm 5$  measuring ranges
- ▶ Accuracy better than  $1 \mu\text{m}$
- ▶ Excellent repeatability, better than  $0.25 \mu\text{m}$
- ▶ Multiple Configurations with tops, tips and tool holders
- ▶ IP65 Sealing
- ▶ Spring and pneumatic actuation

Solartron's Block Gauges make precision measurements of bores and cavities a simple and reliable process. More generally, the use of these devices is recommended in applications where space and access is limited and where the use of axial probes is not possible. The 2 mm Block Gauge is only 8 mm wide.

The Block Gauges offer unrivaled ruggedness, accuracy and repeatability. All three units are extremely versatile and provide datum surfaces, all the adjustments required for precision gauging applications. Block Gauges have robust precision linear bearings with minimal clearance, which limits unmeasured movements maintaining good repeatability even when the contact tip is mounted off center.



## Spring and Pneumatic Configurations

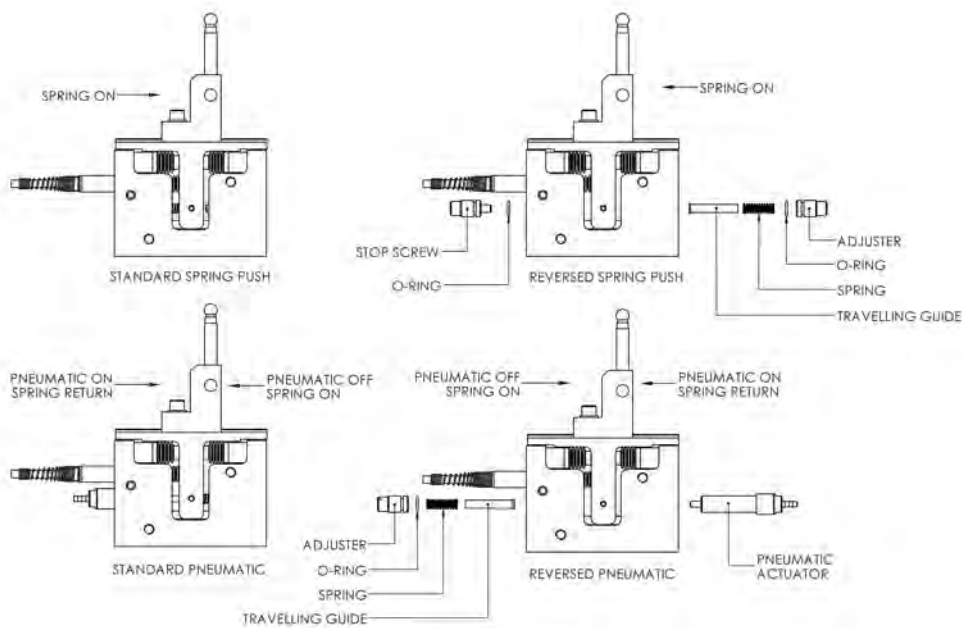

Spring and Pneumatic kits enable the automatic loading of components. Pneumatic actuation coupled with a spring controls the tip force for accurate measurements.



# SPECIALIST TRANSDUCERS

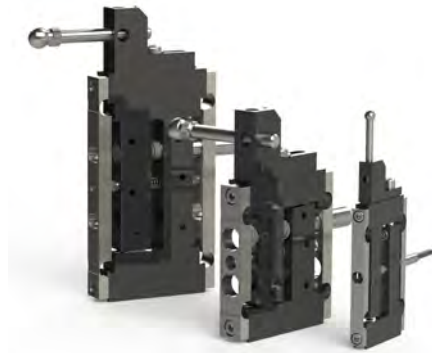

## AU - Flexures - Spring and Pneumatic

- ▶  $\pm 0.5$  &  $\pm 1$  measuring ranges
- ▶ Accuracy better than  $1 \mu\text{m}$
- ▶ Excellent repeatability, better than  $0.25 \mu\text{m}$
- ▶ Multiple Configurations with tops, tips and tool holders
- ▶ IP65 Sealing
- ▶ Spring and pneumatic actuation, pneumatic ( $\pm 0.5$  &  $\pm 1$  mm only)
- ▶ Removable leaves for ease of repair

Parallel Flexures with high resolution and excellent repeatability make Solartron's Flexure Transducers the first choice for high speed precision gauging. With no sliding moving parts, the flexure will maintain performance for millions of cycles and are virtually free from hysteresis.

Flexures can be mounted such that there is little or no stress through the gauge line enabling precision profiling of moving materials, such as rotating shafts, brake discs etc. With resolution better than  $0.05 \mu\text{m}$  at speeds up to 3906 readings per second, the flexure with Orbit<sup>®</sup> provides an excellent dynamic solution.

on centre ■

off centre ■

Repeatability AU/0.5 & AU/1	
On centre	< $0.1 \mu\text{m}$
Off centre	< $0.5 \mu\text{m}$

Application:  
Rod Diameter

Application:  
Bearing Check

Application: Connecting Rod



## AUS - Single Leaf Flexures

- ▶  $\pm 0.25$  mm measuring range
- ▶ Accuracy better than  $1 \mu\text{m}$
- ▶ Normal or reverse actions
- ▶ IP65 Sealing
- ▶ Extension arms
- ▶ Spring actuation

Reverse Spring Application

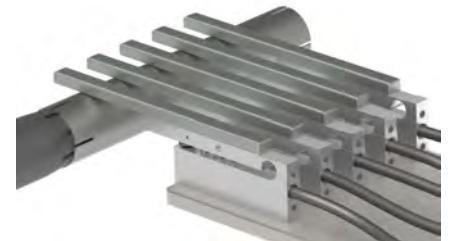

With the same advantages as the parallel flexure the single leaf flexure offers the gauge builder access to even more measurement points. With careful use of extension arms measurements can be made inside slots or between features, where a conventional pencil probe cannot reach.

## Block Gauge and Flexure Accessories



**Tip** (see page 32)  
Standard M2.5 thread

**Tip carriers**  
4 mm  $\varnothing$ , choice of 20, 30, 40 mm length (all). 6 mm  $\varnothing$ , choice of 20, 30, 40 mm length (5 & 10 mm block gauges only)

**Tool holders**  
4 mm bore (all) 6 mm (5 & 10 mm block gauges only)



**Pneumatic actuator**  
Block gauges and flexure gauges are supplied without pneumatic actuators as standard. Please order separately.



**Alternative Springs**  
A set of springs (of different forces) is included with each gauge. Replacements can be ordered individually or as sets.

# TECHNICAL SPECIFICATIONS

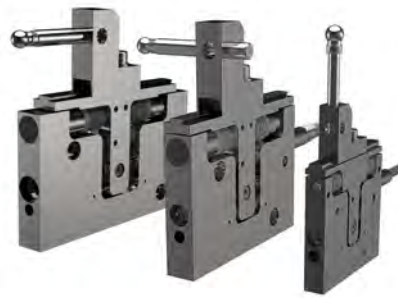

SPRING PUSH AXIAL CABLE <i>(Note 1)</i>		BLOCK GAUGES		
Spring Push Axial Cable		BG/1/S	BG/2.5/S	BG/5/S
Spring Push Radial Cable		BGR/1/S	BGR/2.5/S	BGR/5/S
Pneumatic Axial Cable		All Block gauges can be converted to pneumatic operation using the pneumatic cylinder accessories - page 17		
Pneumatic Radial Cable				
<b>MEASUREMENT PERFORMANCE</b>				
Measurement Range (mm)		±1	±2.5	±5
Linearity (% of Reading)	<i>(Note 2)</i>	0.50	0.50	0.50
Linearity (µm)	<i>(Note 2)</i>	1	2.5	5
Maximum Repeatability (µm)	<i>(Note 3)</i>	<0.25	<0.25	<0.5
Resolution (µm)	<i>(Note 4)</i>			
Pre Travel (mm)	<i>(Note 5)</i>	±0.25	±0.5	±1
Post Travel (mm)	<i>(Note 6)</i>	0.50	0.50	0.50
Tip Force (N)	<i>(Note 7)</i>			
Spring Push ±20 %		1.5	1.5	1.5
Pneumatic ±20 % at 2 bar	<i>(Note 8)</i>	2.1 @ 3 bar	3.3 @ 2 bar	
Temperature Coefficient %FS/°C		0.20	0.50	1.00
<b>ELECTRICAL INTERFACE</b> <i>(Note 9)</i>				
LVDT Sensitivity - Plugged ±0.5% (mV/V/mm)		200	80	40
LVDT Sensitivity - Unplugged ±5% (mV/V/mm)		210	150	105
Half Bridge Sensitivity - Plugged ±0.5% (mV/V/mm)		73.5	29.4	14.7
Half Bridge Sensitivity - Unplugged ±5% (mV/V/mm)		83	82	51
LVDT Energising Current ±5% (mA/V)		1.8	2	2
Half Bridge Energising Current ±5% (mA/V)		1	1	1.2
<b>ENVIRONMENTAL</b>				
Sealing for Probe				
Storage Temperature (°C)				
Operating Temperature (°C)				
Probe Life				Up to 100 million
<b>MATERIALS</b>				
Probe Body				
Probe Tip Options				
Gaiter				
Cable				Standard 2m length, Standard cable has PUR

- ▶ Note 1: Product Descriptions shown are for LVDT probes. For Half Bridge add H to the end e.g. AU/1/SH. All performance parameters identical except sensitivity
- ▶ Note 2: Accuracy is either µm or % reading, whichever is greater
- ▶ Note 3: Repeated operation against a carbide tip 3x standard deviation from average (99%) - On axis with 20 mm tip holder
- ▶ Note 4: Resolution depends on the conditioning electronics used
- ▶ Note 5: Distance from the fully out position to start of calibrated measuring range

# TECHNICAL SPECIFICATIONS



PARELLEL FLEXURE		SINGLE FLEXURE
AU/0.5/S	AU/1/S	AUS/0.25/S
AUR/0.5/S	AUR/1/S	AUSB/0.25/S
AU/0.5/P	AU/1/P	
AUR/0.5/P	AUR/1/P	
±0.5	±1	±0.25
0.50	0.50	±0.3
0.5	1	
0.15	0.15	<0.1
0.075	0.075	0.02/0.03
0.47	0.4	0.05/0.1
1.50	1.50	0.9/1.56
1.00	1.00	
0.01	0.01	
200	200	196
269	210	Not Available
73.5	73.5	
88	88	
1.8	1.8	2.3
1	1	
IP65		
-20 to +80		
+5 to +80		
cycles depending on application, typical 10 million in most applications		
Stainless Steel or aluminum		
Nylon, Ruby, Silicon Nitride, Tungsten Carbide		
Fluoroelastomer or Silicon		
sheath, nylon braided, steel braided or armoured options available		

- ▶ Note 6: Distance from the end of the calibrated measuring range to the fully in position
- ▶ Note 7: Tip force is at the midpoint of the measuring range
- ▶ Note 8: Block Gauge tip force depends on orientation, springs used, weight of tip holder, tip air pressure
- ▶ Note 9: LVDT probes are calibrated at 3 V, 5 kHz into a 10 kΩ load (100 kΩ unplugged). Half Bridge at 3 V, 10 kHz into a 2 kΩ load (1 kΩ unplugged) The probes will operate at energising voltages between 1 and 10 V and frequencies between 2 and 20 kHz but the performance is not specified.

# MINI PROBE



## AM - SPRING ONLY

- ▶  $\pm 0.25$  &  $\pm 0.5$  mm measuring ranges
- ▶ Half Bridge Only
- ▶ Excellent repeatability in both planes of operation
- ▶ Strong frame enables rotation in bores
- ▶ Various tip options
- ▶ Compact size
- ▶ Simple installation

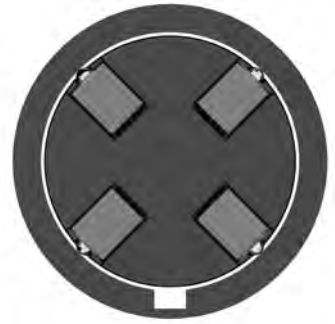

The Mini Probe is a compact, low profile transducer that is ideal for measurement in confined spaces, such as bores. The transducer is based on a parallel spring structure that ensures excellent repeatability over a long working life, even when rotated in bores that have key slots or lubrication ports.

A Tungsten Carbide contact tip is fitted as standard, but a selection of customer replaceable tips with an M2 thread is available for special applications.

Repeatability depends on the alignment of the mini probe whether on axis or cross axis as shown in the diagram.



Mini Probe Actual Size

Application: Check Camshaft Bearings and Alignment



# TECHNICAL SPECIFICATIONS

PRODUCTS				
Spring Push	AM/0.25/S		AM/0.5/S	
MEASUREMENT PERFORMANCE				
Measurement Range (mm)	±0.25		±0.5	
Linearity %FSO	1.0			
Repeatability (µm)	On Axis	Cross Axis	On Axis	Cross Axis
Range: 0-100 µm nominal	0.1	0.1	0.1	0.1
Range: 100-250 µm nominal	0.25	0.15	0.1	0.1
Range: 250-500 µm nominal	0.5	0.25	0.15	0.15
Range: 500-1000 µm nominal	N/A	N/A	0.3	0.2
Resolution (µm)	Depends on electronics			
Pre Travel (mm)	0.01 to 0.02		0.015 to 0.025	
Post Travel (mm) (Min)	0.07		0.07	
Tip Force (N) at Middle of Range ±20%	0.85		0.85	
Temperature Coefficient %FS/°C	0.08		0.08	
ENVIRONMENTAL				
Sealing for Probe	IP65			
Storage Temperature (°C)	-20 to +80			
Probe Operating Temperature with Gaiter (°C)	+5 to +80			
Shock	Do not subject to excessive shock - follow instructions when installing and adjusting			
MATERIAL				
Probe Body	Steel			
Probe Tip (options)	Ruby, Silicon Nitride, Tungsten Carbide			
Gaiter	Fluoroelastomer			
Cable	PUR			
ELECTRICAL				
Operating Frequency	13			
Load (kΩ)	2			
Operating Voltage rms	3			
Plugged Sensitivity mV/V/mm (+/- 0.5%)	76			
MINIMUM CABLE BEND RADIUS mm				
Static (fixed installation)	5			
Dynamic (continuous flex)	12.5			

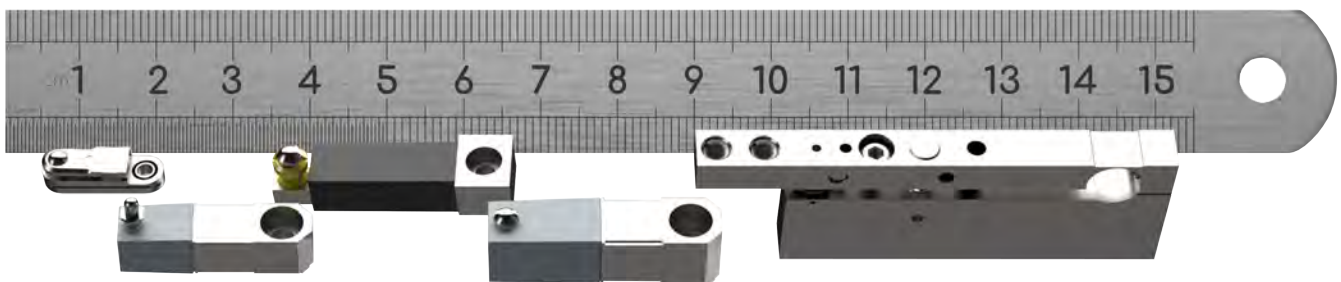

# CONDITIONING ELECTRONICS

Conditioning electronics must often be added to a LVDT or Half Bridge sensor to interface with real world environments.

Solartron Metrology's range of conditioning electronics offers users the ability to connect and configure LVDT and Half Bridge inductive sensors into an almost infinite number of combinations. Outputs include voltage, current loops (4-20 mA) and TTL.

For optimum performance in terms of transducers and electronics please consider Solartron Metrology's Orbit<sup>®</sup>3 Digital Measurement System which out performs the conventional analogue LVDT and Half Bridge sensors in all aspects.

## INTERNAL OR EXTERNAL CONDITIONING

Solartron have transducers with internal conditioning electronics that provide a voltage or current output. Solartron also provide a range of conditioning modules which can be connected to transducers.

### INTERNAL CONDITIONING

- ▶ Compact Design
- ▶ Only one Product to Mount
- ▶ Output type fixed from factory
- ▶ Temperature Range 0°C to 60 °C (hotter or colder environments not recommended)
- ▶ Limited range of sensors  
(See sensor specification for output options)

### EXTERNAL CONDITIONING

- ▶ Range of Options
- ▶ DC or AC Powered
- ▶ Output Adjustable (gain and offset)
- ▶ Probe can operate in hotter or colder environments, with signal conditioning removed at distance
- ▶ Function with all Solartron Probes and most 3rd party LVDT sensors



### EXTERNAL CONDITIONING

The range comprises of the OD products, which are housed in boxes in metal or plastic enclosures and can be easily mounted, the DRC conditioning module, which is a DIN rail mount option, and the In Line products such as the BICM and the ATM TTL converter, which provides differential square wave signals perfect for simple PLC interfaces.

Customised or special products will always be considered when there is not an exact fit in our standard product range.

In Line conditioning uses less space than box mounted conditioning, however care must be taken to ensure that the in line conditioning can be supported and will not be subject to vibration or shock.

# CONDITIONING ELECTRONICS



## OD SERIES

The OD series of conditioning units is used to interface with Solartron's sensors to provide different functions to suit different applications. The **OD2** is a two wire 4-20 mA signal conditioner.

It is designed for signal transmission over long distances due to low noise susceptibility. The **OD4** (OD5 is a mains powered equivalent) is powered from a single 10 to 30 VDC supply. The outputs are fully adjustable for offset and gain.

## DRC

The DRC is a DIN rail mounted version of the OD4 and provides all of the features with the convenience of a DIN rail mount.



## BICM IN LINE MODULE

The BICM provides a simple low cost in line conditioning unit.

This is ideal when the transducer set up is unlikely to require adjustment. For use in harsh environments, an IP67 version is available.



## OUTPUTS

The correct selection of outputs is critical to accurate noise free transmission. All analogue signals are more prone to interference than digital transmission methods such as TTL. Use of current as a transmission method can offer significant advantages over long cable runs. With all external conditioning it is possible to adjust both the offset voltage and the gain to give numerous output combinations and to increase sensitivity over a pre defined measurement range.

# CONDITIONING ELECTRONICS

## STANDARD OUTPUTS

Transducer with full range A to B.



## SCALED (MAGNIFIED) OUTPUTS

Total Measuring Range



Output can be scaled over a limited range to increase sensitivity and resolution. For example a range between 1 mm and 1.5 mm could be scaled from 0 V to 10 V.

## PROBE MOUNTED REMOTE FROM ELECTRONICS

Typical Output Range

A	B	
4	20	mA
0	5	V
-10	10	V
2	7	V
-5	4	V

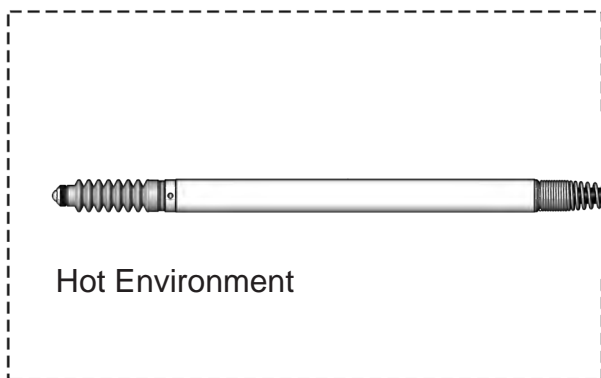
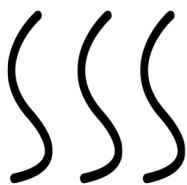



# TECHNICAL SPECIFICATIONS

	OD2	OD4	OD5	DRC	BICM	
<b>POWER REQUIREMENT</b>						
Input Voltage VDC	13-42	10-30	N/A	10-30 V	±15	24 V
Input Voltage VAC	N/A	N/A	90-264	N/A	N/A	N/A
Input Current (mA)	<30	140 to 10 V	250	160 at 10 V	±12	24
	-	50 at 30 V	-	70 at 30 V	-	-
Frequency (Hz)	N/A	N/A	47-63	N/A	N/A	N/A
<b>TRANSDUCER INTERFACE</b>						
Primary Voltage (Vms)	0-9	-	3	-	1.2 - 21	
Primary Frequency (kHz)	5 or 13	2.5 or 5		5, 10 or 13	2.5 to 20	
Input Range	30-530 mV/V (Note 1)	55 to 5000 mV			up to 3.5	
Input Load (kΩ)	2	2, 10, 100		2, 100	100	
Options	Forward and reverse			see (Note 2)		
<b>OUTPUT (Note 4)</b>						
Voltage Output VDC	-	±10 VDC, ±5 VDC, 0-5 VDC, 0-10 VDC				
Current Output mA	4-20	Up to ±20 into 150 Ω load				-
Output Ripple	<38 μA rms	<1 mV rms			<14 mV	
Output Offset	Up to 100% maximum gain (coarse and fine adjustment)					
Temperature Coefficient Gain (%FSO/°C)	<0.01				<0.03	
Temperature Coefficient Offset (%FSO/°C)	<0.01				<0.02	
Warm Up (minutes)	15 Minutes					
Linearity (%FSO)	<0.02				<0.1	
Bandwidth (-3dB) (Hz)	25	500Hz, 1 khz				
<b>ENVIRONMENTAL (Note 3)</b>						
Storage Temperature	-40 to +80	-20 to +80			-20 to +80	
Operating Temperature	0 to +60					
IP Rating	65	40	40	None	40/67	40
EMC	Immunity EN61000-6-2 Emissions EN61000-6-3					
<b>MECHANICAL</b>						
Transducer Connections	Terminals	Din Connector		Terminals	Solder or factory fit for IP67	
Power Connections	Terminals	IEC320 C14				
Weight	-					
Material	ABS	Painted Aluminum Box		Plastic	Plastic or Metal (IP67)	
Mounting	Holes			DIN rail	in line	

- ▶ Note 1: For transducers with sensitivity > 250 mV/V, an attenuator is required - contact sales
- ▶ Note 2: Transducer connected via external screw terminal. User can therefore configure options
- ▶ Note 3: For higher environmental levels (and other custom options) contact sales office
- ▶ Note 4: For custom options contact Sales Office

# SI3000 Readout

Specially designed to work with Solartron Transducers, the SI3100 provides the user with 1-2 channel solutions for small systems. The readout has an intuitive menu systems for ease of set up and can be programmed to display readings, alarms, limits and other metrology functions. With discrete I/O and serial interfaces these readouts provide a neat interface to other systems like PLC's.



## SI3100 - FEATURES

- ▶ Intuitive menu
- ▶ 2 LVDT inputs
- ▶ Mathematical functions
- ▶ Auto Colour Change for in /out limit range
- ▶ RS232 Connectivity
- ▶ Discrete I/O

## Internal or External Conditioning

PERFORMANCE AND FUNCTIONS	SI3100 LVDT / SI3200 HALF BRIDGE
Number of Transducers	1 or 2
Display	1 Channel
Length / Resolution	$\pm xx.xxxxx$ (mm) $\pm x.xxxxxx$ inches
Indications	mm / inch, Lower and Upper Limits, Out of Range, Measurement Type and Mode
Keypad	Print, Zero, Preset, Peak, Hold Track, Menu
Measurement Type	A, B, A+B, A-B, (A+B)/2, (A-B)/2, (B-A)/a
Data Logging	10,000 readings via discrete inputs or 1ms to 24 hour time interval
INPUT AND OUTPUTS	
Serial ASCII Interface	Yes
Inputs	Six isolated
Outputs	Six isolated
Analogue Output	User selectable; Voltage or 4-20 mA
POWER AND ENVIRONMENTAL	
Operating Voltage	24 VDC $\pm$ 10%
Power for Transducers	LVDT interface 5k Hz or 10 kHz 3 V rms / Half bridge 10 kHz / 13 kHz
Sealing Front Panel	IP65
Sealing Case	IP51
Sealing Rear Connections	IP51
Operating Temperature (°C)	5 to +50
Storage Temperature (°C)	-20 to 50
EMC	Immunity EN61000-6-2 Emissions EN61000-6-3
MECHANICAL	
Mounting	Bench or Panel
Dimensions WxHxD	Without Bezel 134x67x160 With Bezel 144x76x177

For more readout functionality consider the Solartron SI5500 readout with up to 31 Orbit® Digital Probes and user programmable metrology equations – Refer to Orbit® Catalogue and / or website.

# ACCESSORIES

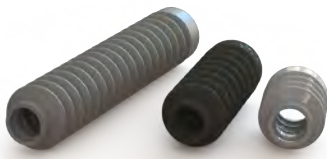

## REPLACEMENT GAITERS

Gaiters can be replaced when damaged. Only standard pneumatic push probes require gaiter rings.

SPRING PUSH	PART NUMBER	PNEUMATIC PUSH	PART NUMBER
A6G/1/S	205014	N/A	N/A
AX/1/S	204851	AX/1/P	802691
AX/1.5/S	204851	N/A	N/A
AX/2.5/S	204894	AX/2.5/P	802692
AX/5/S	204860	AX/5/P	802693
AX5/1/S	204860	AX5/1/S	802693
AX/10/S	205906	AX/10/P	803235

## RETROFIT RIGHT ANGLE ADAPTOR

For use with spring push gauging probes. Part Number: 203224

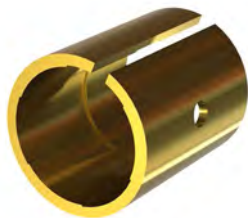

## CLAMPING COLLET

For use with all 8 mm diameter probes. The clamping collet distributes the clamping forces evenly around the probe body. Using the supplied grub screw, the probe can be loosened while holding the collet in place.  
Part number: 806466-SX (10 mm)  
805048-SX (9.5 mm)

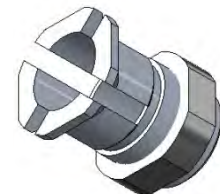

## CLAMPING TOOL

## IMPERIAL ADAPTOR SLEEVES

Adaptor Sleeves can be used to increase the body diameter of 8 mm sensors to 9.512 (3/8"). Available in lengths from 12 to 127 mm.

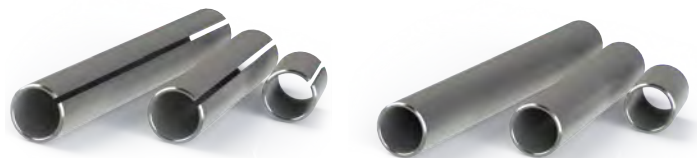

## EXTENSION CABLE

Extension cables for analogue sensors with 5 pin DIN 240° connectors are available for LVDT and Half Bridge types.

# TRANSDUCER DIMENSIONS

## Standard Spring Push (AX/S(H))

	AX/1/S	AX5/1/S	AX/1.5/S	AX/2.5/S	AX/5/S	AX/10/S
A	43.00	75.00	58.00	63.00	87.00	127.00
C	4.00*	4.25*	4.50*	4.50*	4.50*	3.00*
B1	14.00	25.50	14.50	18.00	25.50	45.00
B2	11.00	14.50	10.50	12.00	14.50	24.00
D	29.50	61.50	44.50	49.50	73.50	113.50

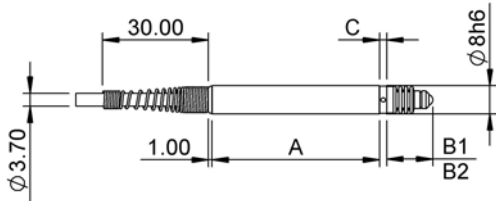

## Feather Touch Spring Push (AT/S(H))

	AT/1/S	AT5/1/S	AT/1.5/S	AT/2.5/S	AT/5/S	AT/10/S
A	43.00	75.00	58.00	63.00	87.00	127.00
C	4.00*	4.25*	4.50*	4.50*	4.50*	3.00*
B1	14.00	25.50	14.50	18.00	25.50	34.00
B2	11.00	14.50	10.50	12.00	14.50	13.00
D	29.50	61.50	44.50	49.50	73.50	113.50

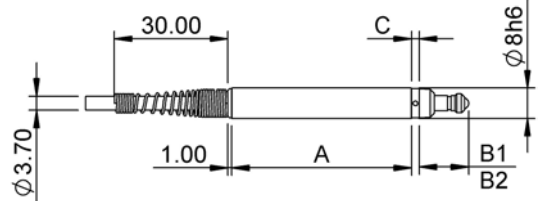

## Pneumatic Push (AX/P(H))

	AX/1/P	AX5/1/P	AX/2.5/P	AX/5/P	AX/10/P
A	49.00	84.00	71.00	96.00	127.00
C	2.00	2.00	2.00	2.00	3.00*
B1	14.25	25.50	18.00	25.50	45.00
B2	11.25	14.50	12.00	14.50	24.00
D	35.50	70.50	57.50	82.50	113.50

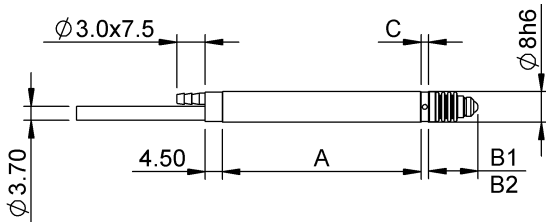

## Feather Touch Pneumatic Push (AT/P(H))

	AT/1/P	AT5/1/P	AT/2.5/P	AT/5/P	AT/10/P
A	49.00	84.00	71.00	96.00	127.00
C	2.00	2.00	2.00	2.00	3.00*
B1	14.25	25.50	18.00	25.50	34.00
B2	11.25	14.50	12.00	14.50	13.00
D	35.50	70.50	57.50	82.50	113.50

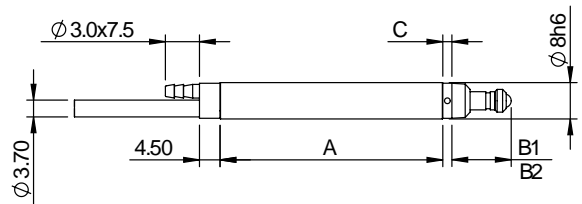

## Vacuum Retract (AX/V(H))

	AX/1/V	AX5/1/V	AX/1.5/V	AX/2.5/V	AX/5/V	AX/10/V
A	43.00	75.00	58.00	63.00	87.00	127.00
C	4.00*	4.25*	4.50*	4.50*	4.50*	3.00*
B1	14.00	25.50	14.50	18.00	25.50	45.00
B2	11.00	14.50	10.50	12.00	14.50	24.00
D	29.50	61.50	44.50	49.50	73.50	113.50

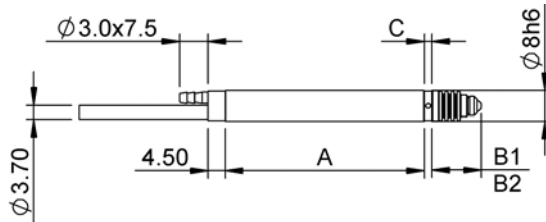

## Gaiger Independent Pneumatic (AJ/P(H))

	AJ/1/P	AJ5/1/P	AJ/2.5/P	AJ/5/P	AJ/10/P
A	49.00	84.00	71.00	96.00	127.00
C	7.00	7.00	7.00	7.00	4.00*
B1	16.25	27.50	20.00	27.50	46.00
B2	13.25	16.50	14.00	16.50	25.00
D	35.50	70.50	57.50	82.50	113.50

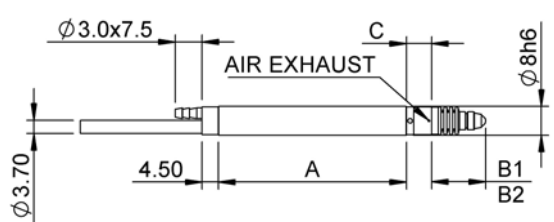

## Radial Cable Outlet Plastic Adapter

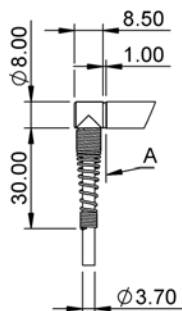

## Radial Cable Outlet Fixed / Spring Push

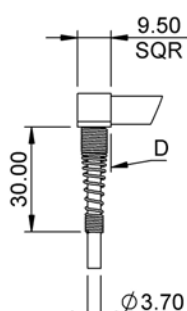

## Radial Cable Outlet Fixed / Pneumatic

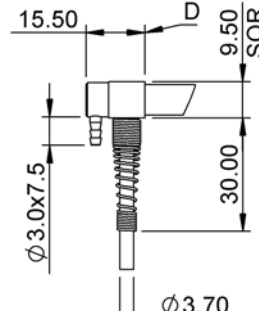

## Radial Cable Outlet St / Steel Braided

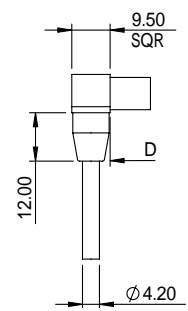

A - Case length for axial cable outlet  
 B1 - Fully extended bearing assembly  
 B2 - Fully retracted bearing assembly

C - Fixed part of the bearing assembly,  
 D - Case length for radial cable outlet only  
 \* - Variable dimension, tolerance  $\pm 0.25$  mm



# TRANSDUCER DIMENSIONS

Ultra Feather Touch Spring Push (AW/S)

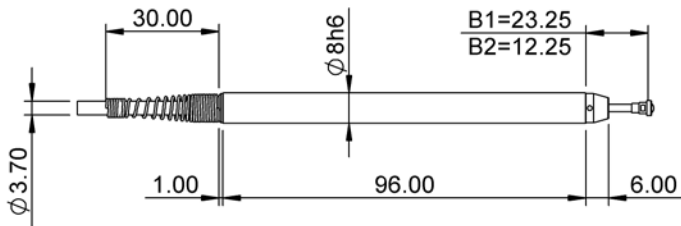

Ultra Feather Touch Pneumatic Push/Vacuum Retract (AW/P / AW/V)

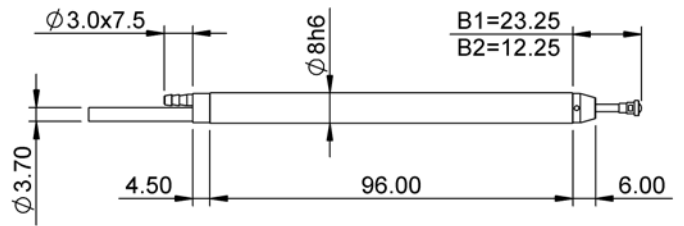

6mm Diameter Body Spring Push (A6G/S)

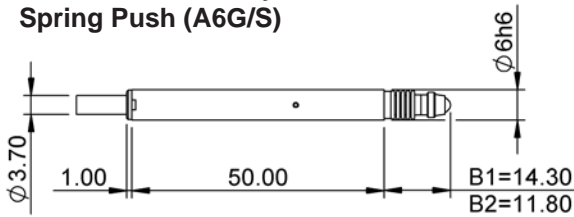

6mm Diameter Body Gaiter Independent Pneumatic Push (A6J/P)

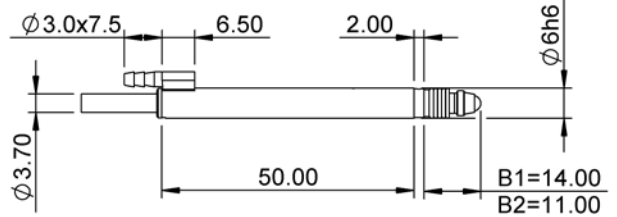

Miniature Spring Push (AX/0.5/S)

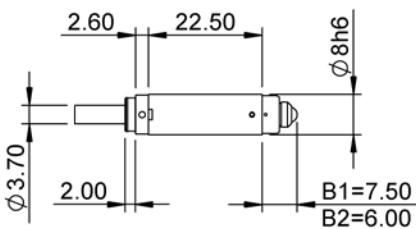

Mini Probe (AM/0.25/S)

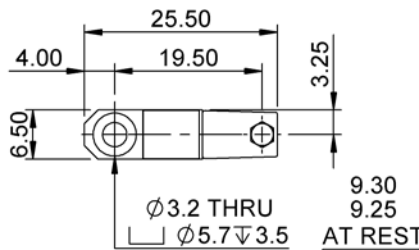

Mini Probe (AM/0.5/S)

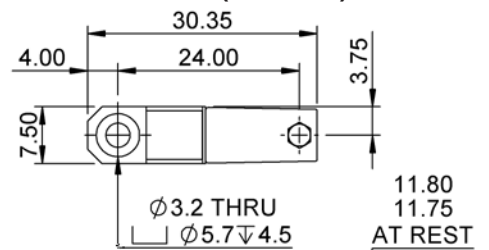

Miniature Spring Push (AXR/0.5/S)

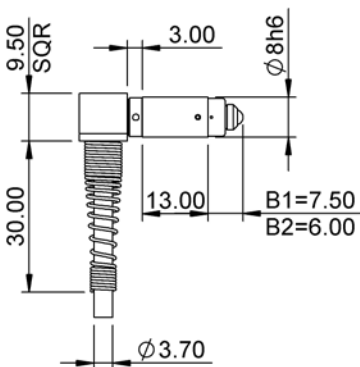

G Series Spring Push (VG/IG/WG)

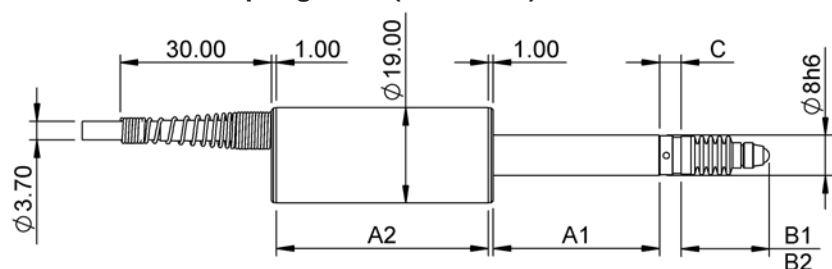

Miniature Spring Push (AX/0.25/S)

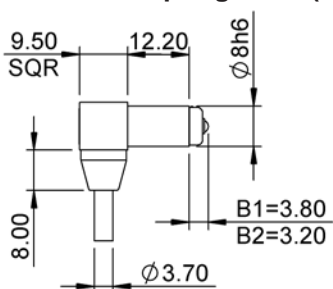

	VG/2/S WG/2/S	VG/5/S WG/5/S	VG/10/S WG/10/S	VG/20/S WG/20/S	IG/2/S	IG/5/S	IG/10/S	IG/20/S
A1	28.00	28.00	52.00	92.00	33.00	33.00	57.00	97.00
A2	47.00	47.00	47.00	47.00	42.00	42.00	42.00	42.00
B1	16.00	20.00	27.50	47.00	16.00	20.00	27.50	47.00
B2	13.00	14.00	16.50	26.00	13.00	14.00	16.50	26.00
C	3.75*	4.25*	4.25*	3.00*	3.75*	4.25*	4.25*	3.00*

# TRANSDUCER DIMENSIONS

## Flexure Gauge (AU(R)/0.5/S(P))

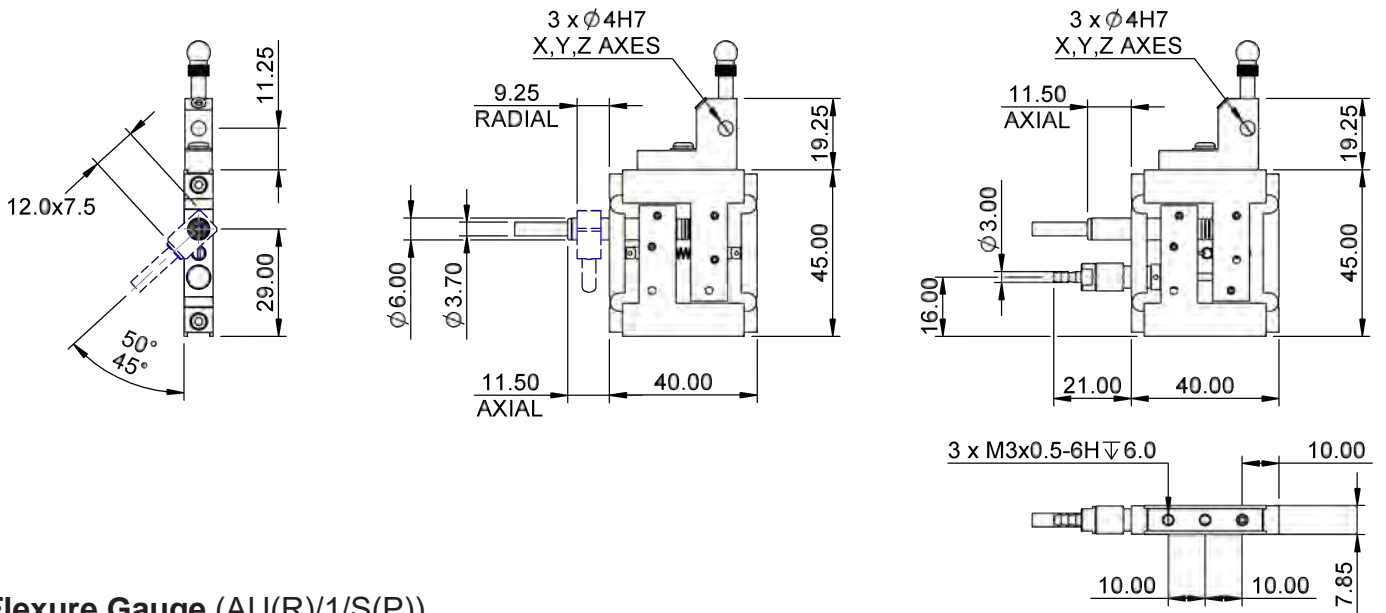

## Flexure Gauge (AU(R)/1/S(P))

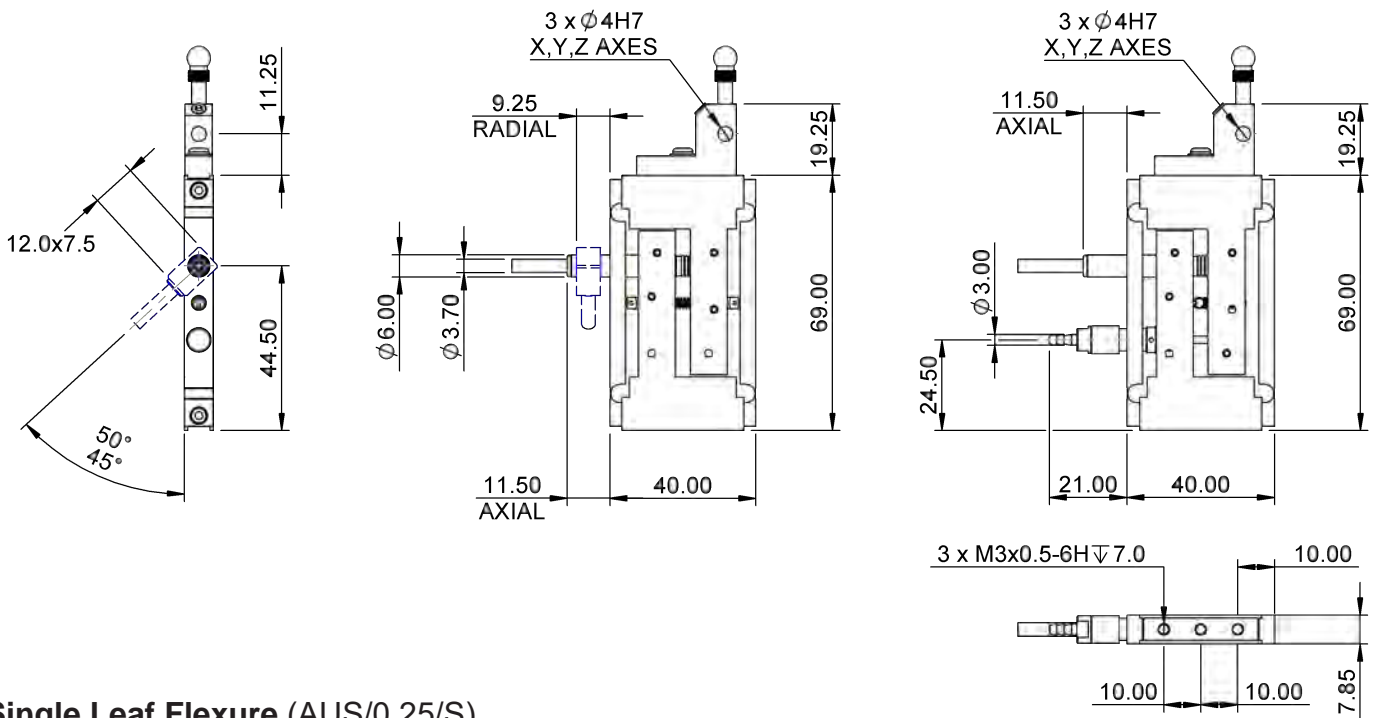

## Single Leaf Flexure (AUS/0.25/S)

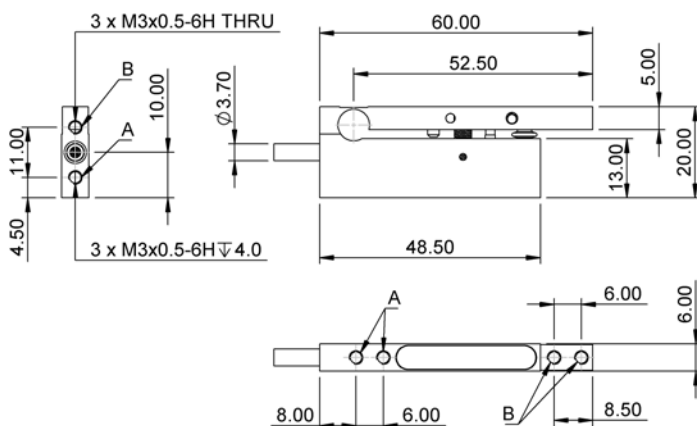

# TRANSDUCER DIMENSIONS

## Block Gauge (DK(R)/2/S(P))

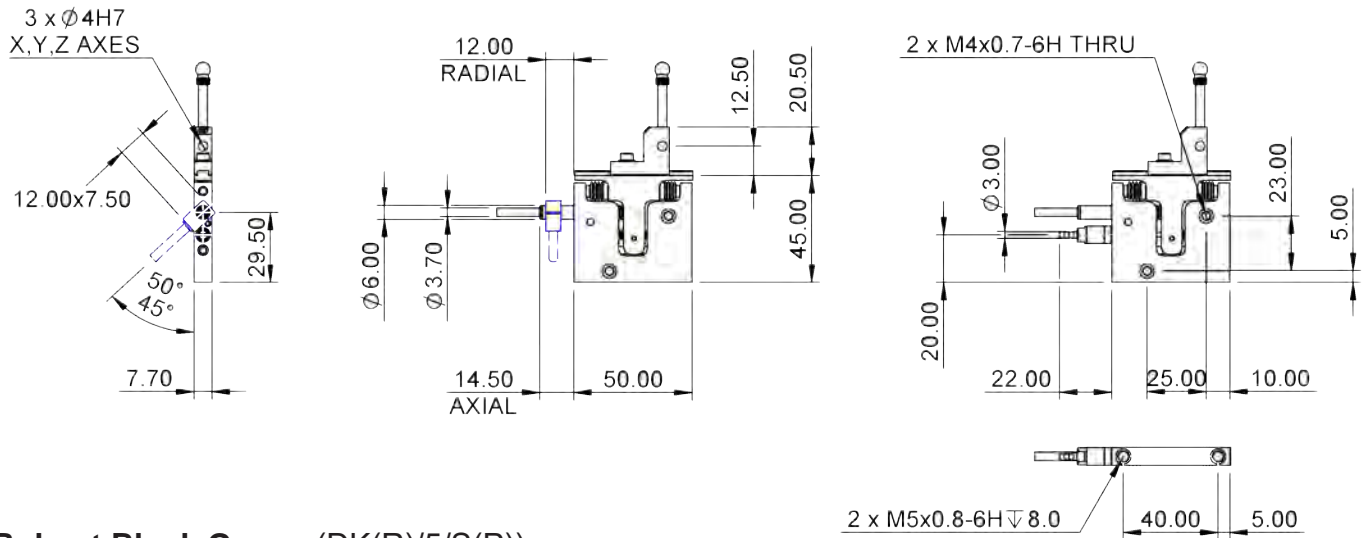

## Robust Block Gauge (DK(R)/5/S(P))

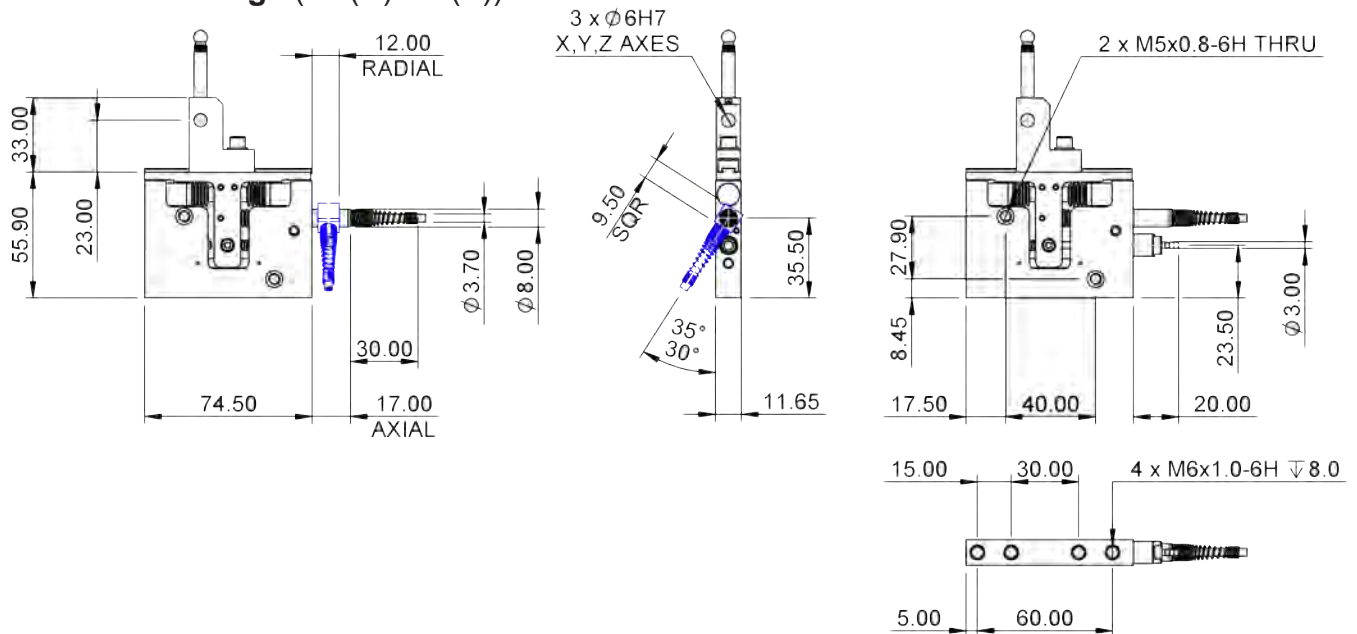

## Robust Block Gauge (DK(R)/10/S(P))

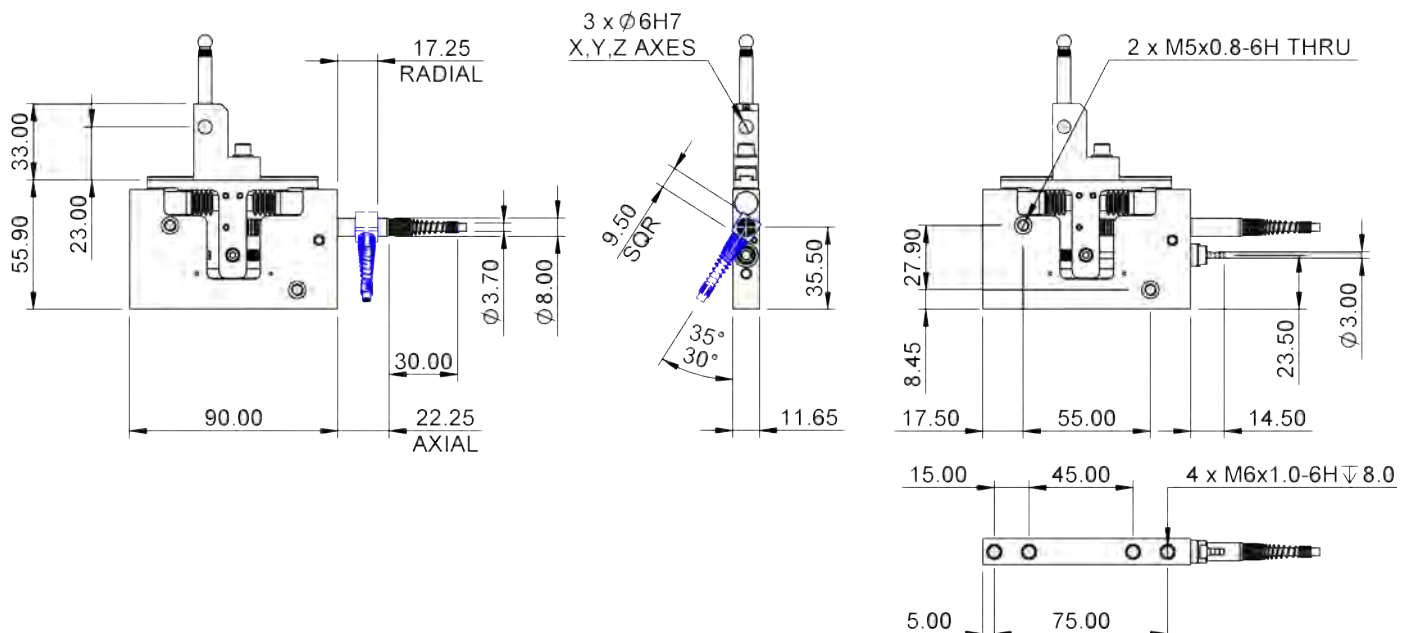

# TRANSDUCER TIPS

Contact size, shape and material are critical to ensure accurate measurements, for example a flat or knife tip makes measuring external diameters much simpler than using a point tip as probe alignment is not as critical. Tungsten Carbide is a good general purpose material while ruby offers longer life. Silicon Nitride is good for aluminium as Tungsten Carbide can mark aluminium parts.

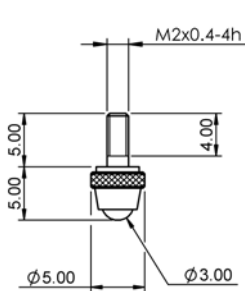

Ø 3.00 mm Ball

Tip Material	Part no.
T.Carbide	806341
Ruby	807428
Nylon	807429
Silicon Nitride	807430

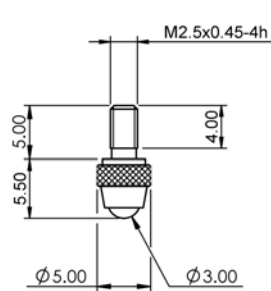

Ø 3.00 mm Ball

Tip Material	Part no.
T.Carbide	804979
Ruby	804807
Nylon	805181
Silicon Nitride	804983

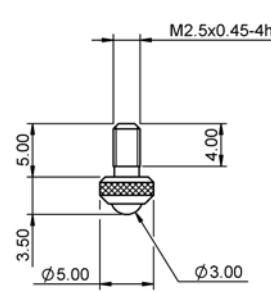

Ø 3.00 mm Ball

Tip Material	Part no.
T.Carbide	802605
Ruby	807431
Nylon	803246
Silicon Nitride	807432

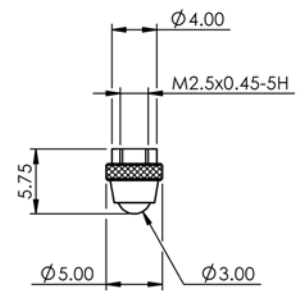

Ø 3.00 mm Ball

Tip Material	Part no.
T.Carbide	804967
Ruby	804966
Nylon	804965
Silicon Nitride	805180

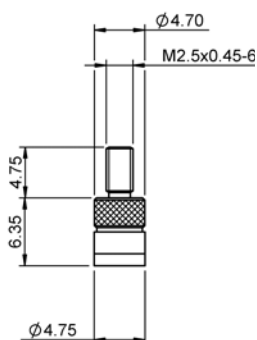

Ø 3.18 mm Ball

Tip Material	Part no.
T.Carbide	008305-033

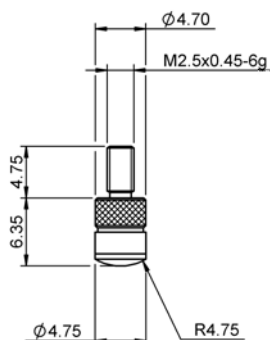

Ø 6.35 mm Ball

Tip Material	Part no.
T.Carbide	008305-034

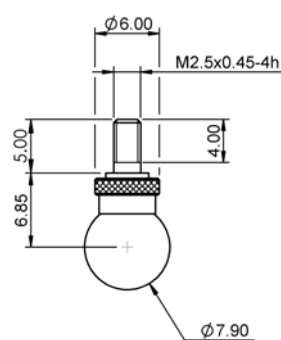

Ø 7.9 mm Ball

Tip Material	Part no.
Ruby	804828

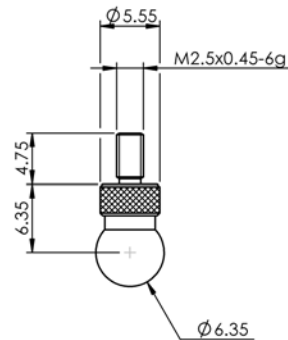

Ø 4.75 mm Dome

Tip Material	Part no.
T.Carbide	008305-005

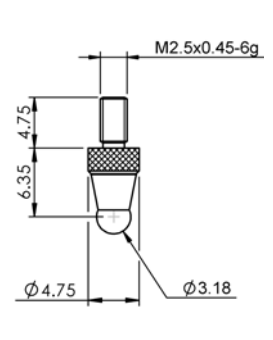

Ø 4.75 mm Flat

Tip Material	Part no.
T.Carbide	008305-004

# TRANSDUCER TIPS

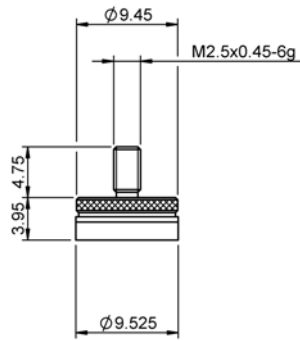

Ø 9.52 mm Flat

Tip Material	Part no.
T.Carbide	008305-007

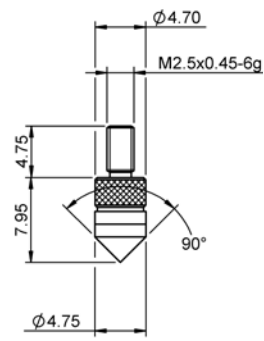

90° Sharp Point

Tip Material	Part no.
T.Carbide	008305-003

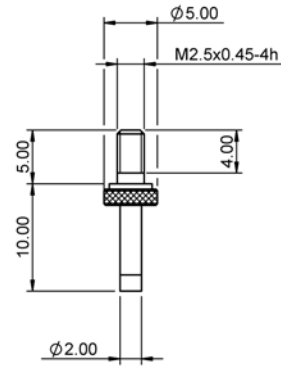

Ø 2.0 mm Pin

Tip Material	Part no.
T.Carbide	206675

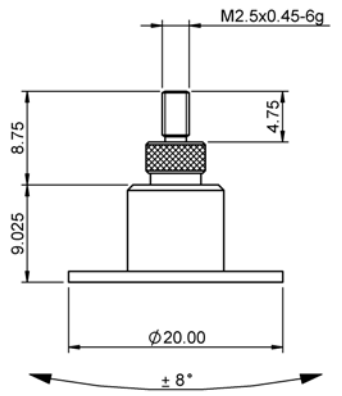

Floating Tip

Tip Material	Part no.
Steel	807434

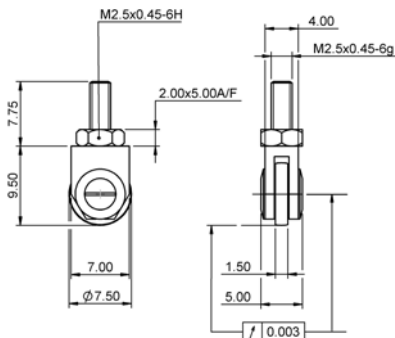

1.5 x Ø 7.5 mm Wheel ø

Tip Material	Part no.
T.Carbide	008305-027

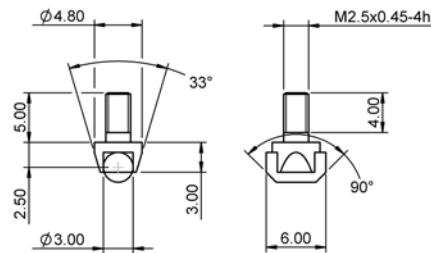

Ø 3.0 mm Roller

Tip Material	Part no.
T.Carbide	209193

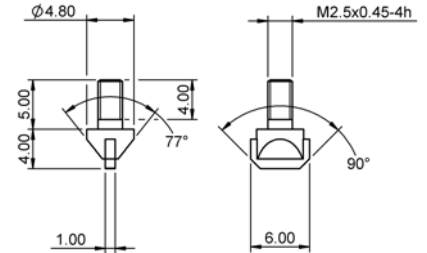

1 x 6 mm Blade Edge

Tip Material	Part no.
T.Carbide	209194

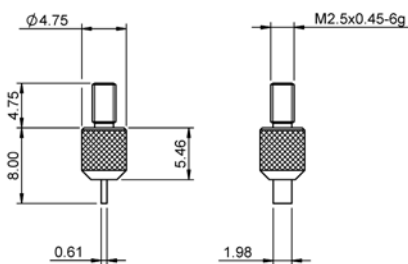

0.6 x 2 mm Blade Edge

Tip Material	Part no.
T.Carbide	008305-035

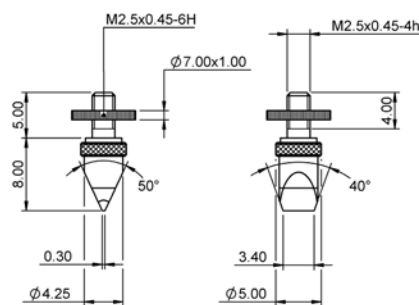

Knife Edge

Tip Material	Part no.
T.Carbide	206674

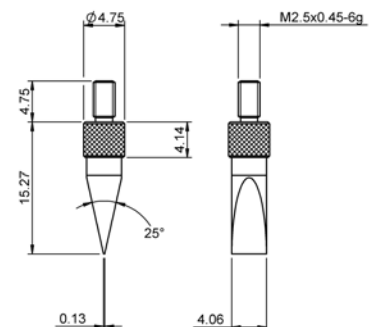

0.1 x 4 mm Knife Edge

Tip Material	Part no.
T.Carbide	008305-036



# ORBIT<sup>®</sup> DIGITAL MEASURING NETWORK

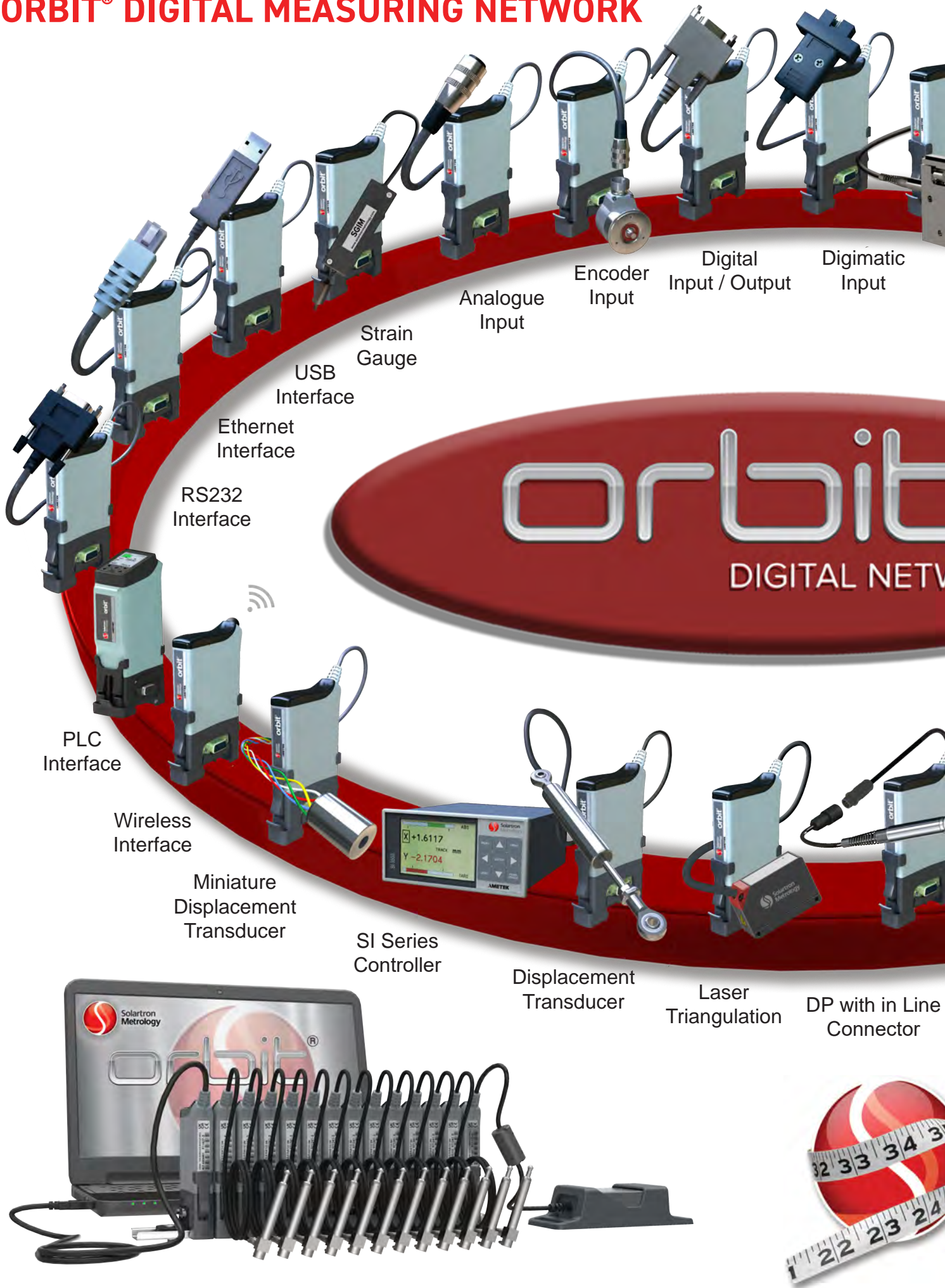

Encoder Input    Digital Input / Output    Digimatic Input

Analogue Input

Strain Gauge

USB Interface

Ethernet Interface

RS232 Interface

PLC Interface

Wireless Interface

Miniature Displacement Transducer

SI Series Controller

Displacement Transducer

Laser Triangulation

DP with in Line Connector

# orbit<sup>®</sup>

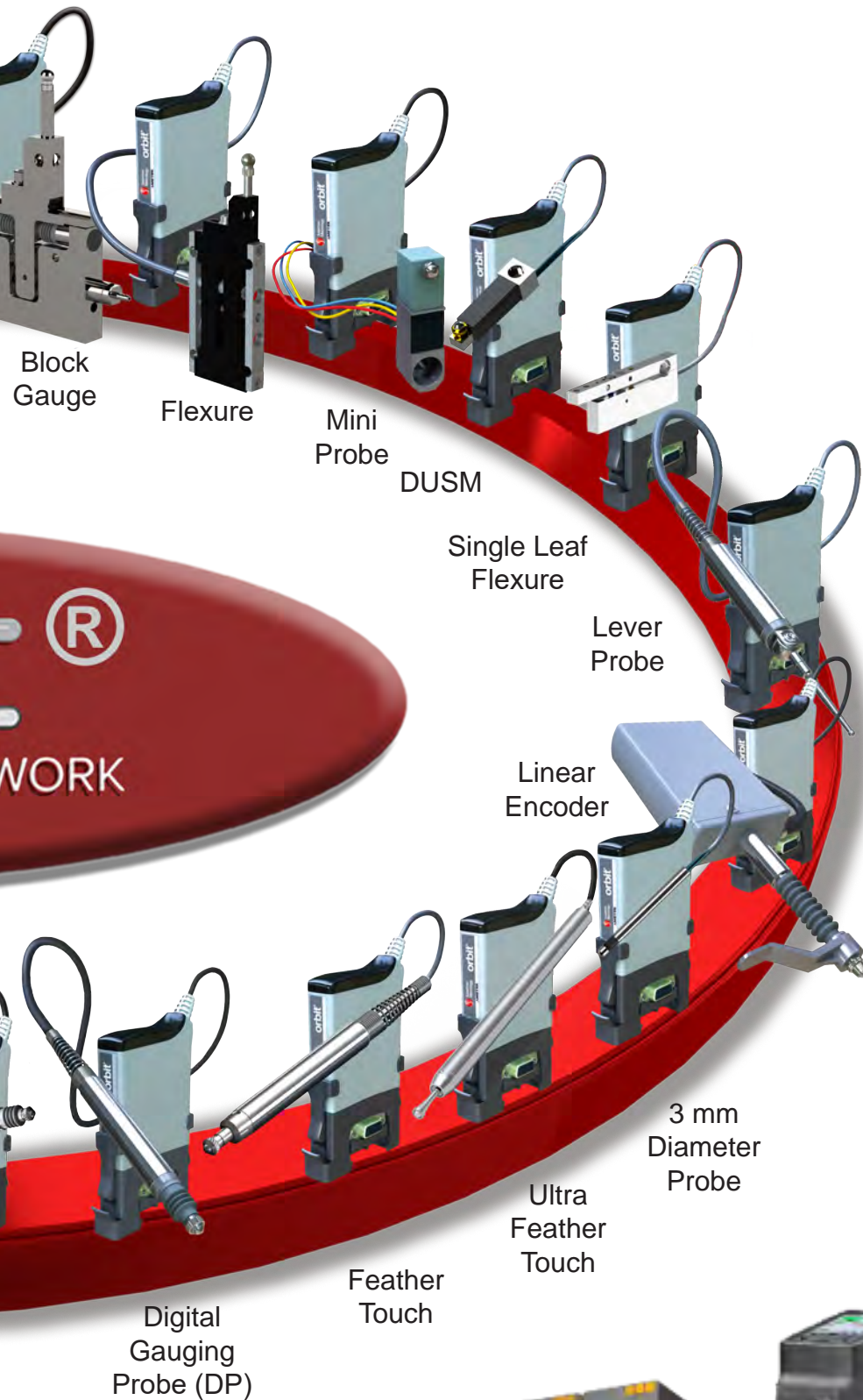

**Higher performance does not mean higher costs.**

Quality standards in industry and research are becoming tighter, while demands for cost savings continue to increase. Orbit<sup>®</sup> provides the way forward for all precision measurement or positioning needs, whether on the production line or in the laboratory.

Orbit<sup>®</sup> provides a complete solution for integrating different measurement position and control sensors smoothly and simply into network solutions.

The Orbit<sup>®</sup> system architecture consists of a rugged mechanical design coupled with a high degree of electrical protection and excellent noise immunity, ensuring valid accurate data when it is needed.

All Solartron products have undergone rigorous testing to ensure a long and productive life.





# ORBIT® DIGITAL MEASURING SENSORS

## WIRELESS HAND TOOLS

The freedom to roam with **Solartron's WiGauge™** brings increased efficiency to gauging stations and work practices. The ability to work without cables means that the gauging process is not restricted by cable length and routing, or the risk of cable damage.

### WIGAUGE™ SINGLE CHANNEL

- ▶ Fit Wi Gauge with bore heads to check inner diameters
- ▶ M10 & M6 mm fixing threads, which fit most common bore heads
- ▶ LCD Screen option
- ▶ < 0.1 µm resolution (user selectable)
- ▶ Multiple WiGauges™ can connect to a single system
- ▶ 10 hours battery life (based on continuous data transmission)
- ▶ Inductive and Plug-In Charging options
- ▶ IP65 protection
- ▶ Pass/fail range lamps
- ▶ Audio indication of data transmission

wigauge™



### WIGAUGE™ MULTI CHANNEL

- ▶ Handle can be integrated with up to 8 Solartron transducers to form multifunctional wireless gauges, such as snap gauges or multi-sensor bore gauges
- ▶ Mounting plate on end of handle to attach custom tooling
- ▶ < 0.1 µm resolution
- ▶ 5 hours battery life (based on continuous data transmission) off charger.
- ▶ Inductive battery charging system
- ▶ IP65 protection (Handle)
- ▶ Audio indication of data transmission



Multi Channel WiGauge™ used with narrow body probes to create a crank gauge



Multi Channel™ used with Mini probes for bore measurement



### WIGAUGE™ WIRELESS CONNECTION MODULE

Use the Wireless Connection Module to output WiGauges™ directly into the Orbit Network. The Wi Gauges can then be run with Orbit GCS and others. Up to 6 WiGauge™ units can be connected to a WCM at once, and all data be saved and synchronized with other Solartron Sensors.

## ORBIT® NON-CONTACT - LASER TRIANGULATION

For applications where a contact gauging sensor is unsuitable, Solartron offers a range of high performance, low cost Non-Contact Laser Triangulation Sensors. This solution is fully compatible with the Orbit® Measurement Network, which can synchronise up to 200 sensors at once.

### LT2

- ▶ High precision for metallic and reflective surfaces
- ▶ Linearity up to 6 µm, with repeatability up to 0.1 µm
- ▶ Sample rate up to 4 khz
- ▶ "Oval" spot that is ideal for checking metallic surfaces
- ▶ "Adaptive Surface Adjustment:" Laser automatically adjusts beam intensity based on surface for optimum repeatability
- ▶ Software Drivers offer different measurement modes and averaging adjustments for peak repeatability

### LT1

- ▶ 25 and 100 mm ranges
- ▶ Linearity up to 12 µm, with repeatability of up to 1 µm
- ▶ Sample rate up to 1 khz
- ▶ Excellent price/performance ratio

orbit®



# ORBIT® READOUTS AND ORBIT® LINEAR ENCODERS

## SI8500

The SI 8500 provides the opportunity to collect measurement data with the purpose of optimizing manufacturing production analysis and control. User interface has been designed to ensure all users the maximum accessible data for industrial measurement applications.

### FEATURES

- ▶ Heavy duty aluminium casing with 10" Touch Screen. Built for an industrial environment.
- ▶ IP64 for front panel with four programmable keys.
- ▶ Connect with up to 64 Orbit Sensors
- ▶ Power up to 10 modules, including contact and non-contact sensors
- ▶ Easy & intuitive setup with touch screen
- ▶ Build your own custom formulas
- ▶ SPC and Mastering functions included
- ▶ I/O Connections for automation
- ▶ USB port for easy data output
- ▶ Footswitch plug
- ▶ Link to 3rd party sensors via Orbit connection modules, including air gauging
- ▶ Benchtop (with stand) or Panel Mount options (VESA Mounting Standard)



## SI100, SI200 AND SI400

The SI100 is a single channel, stand alone system, while the SI200 also connects to an Orbit® probe for two channel measurements and the SI400 connects to up to 3 probes.

### FEATURES

- ▶ Integral Readout with colour LCD Screen and keypad
- ▶ Set tolerance and process limits via keypad
- ▶ Detachable probe plug on housing for easy installation
- ▶ Replace probe with no calibration or reprogramming (Inline plug option)
- ▶ Modbus output (RTU) over RS485 or RS232
- ▶ Programmable discrete I/O (4 inputs, 3 outputs)
- ▶ Multiple formulas available for SI200 (A+B, A-B, etc)
- ▶ Available with all Solartron transducers and lasers
- ▶ 24 VDC Power Supply
- ▶ SI200 and SI400 also available as a Stand Alone unit with no sensor attached to the housing



## ORBIT® LINEAR ENCODERS

The **Digital Linear Encoder** range of gauges consist of high accuracy optical probes designed for use in applications where consistent submicron measurement accuracy is required. In contrast to traditional gauging probes, the accuracy is maintained along the entire measurement range.

- ▶ Spring free, pneumatic, cable release
- ▶ 0.4 µm accuracy
- ▶ 0.05 µm resolution



# GLOSSARY OF TERMS

## ACCURACY

The accuracy of all Solartron Metrology Digital Displacement Sensors, Gauge Probes and Displacement Transducers is quoted as a % of the linear displacement measurement, which is the method that is least open to interpretation (as opposed, for example, to best fit).

## DIRECTION OF LINEAR DISPLACEMENT MEASUREMENT

- ▶ Outward movement is linear displacement from the body of the displacement sensor or displacement transducer.
- ▶ Inward movement is linear displacement towards the body of the displacement sensor or displacement transducer.

## DISPLACEMENT SENSOR TIP FORCE

The tip force of the linear displacement transducer is defined as the force exerted on the item being measured at the mid-point of the displacement transducer measuring range.

## HYSTERESIS

Hysteresis of a gauge probe is the difference from the true measurement when the direction of measurement is reversed.

## LVDT

Linear Variable Differential Transformer Displacement Sensor or Gauge Probes are devices that measure linear displacement. This type of displacement transducer has a reputation for long life with reliable measurements providing a cost-effective solution for many measuring applications. LVDT transducers or gauge probes are used wherever fast and accurate linear measurements are required to ensure good process control.

## LVDT LINEARITY

Linearity is defined as the deviation of an LVDT displacement transducer or Half Bridge sensor's output from a straight line.

## LVDT MEASURING RANGE (CALIBRATED RANGE)

The measuring range over which the LVDT displacement sensor specification is guaranteed. For LVDT transducers this is normally expressed as a measurement either side of the LVDT displacement sensor Electrical Zero.

## LVDT MECHANICAL RANGE

The total physical movement the displacement transducer moving part can travel.

## LVDT RESIDUAL VOLTAGE AT ZERO

The minimum voltage attained for the LVDT transducer electrical zero position. (i.e. the smallest output that can be detected).

## POST-TRAVEL

The mechanical movement from the end of the LVDT measuring range (inwards) to the fully inward position, where the moving element is against a mechanical limit stop.

## PRE-TRAVEL

The mechanical movement from the LVDT transducer fully outward position, (where the moving element is against a mechanical limit stop) to the start of the LVDT measuring range.

## REPEATABILITY

Repeatability is defined as the ability of a sensor to provide measurements within a close distribution on the same measure and carried out in the same direction. Solartron uses a method of establishing repeatability where a side load is applied in four directions to reflect how sensors are used in most applications. Methods of establishing repeatability without applying a side load may produce better results but may not be representative of real life applications.

## SENSITIVITY

This is the specified magnitude of the output with respect to displacement (mm) and energising voltage (V) for an LVDT sensor or Half Bridge displacement transducer. It is expressed in mV/V/mm.





# GLOSSARY OF TERMS

## % FULL RANGE OUTPUT (%FRO)

% Full Range output fits a straight line through zero to the measured characteristic which balances the positive and negative errors from this line. This is known as the "Best Fit Straight Line". The magnitude of this error is then expressed as % of full range and includes any error due to symmetry either side of zero, but does not include any sensitivity error.

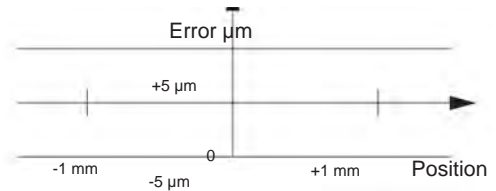

Example:  $\pm 1$  mm transducer with 0.5% full range

## % READING

% Reading defines an error envelope within which the allowable error is proportional to the displacement. This is defined as a % of the displacement being measured with a minimum equivalent to 20% of the maximum displacement that the transducer can measure. This method results in a more stringent performance being required of the sensor operating around the electrical zero than is required with a % FRO.

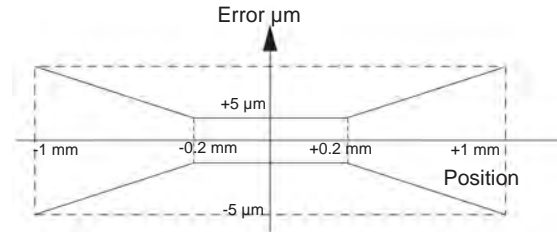

Example:  $\pm 1$  mm transducer with 0.5% reading

For standardised analogue transducers the error envelope is with respect to the nominal transducer sensitivity and therefore the total error includes both linearity and sensitivity errors. For non standardised transducers the error curve is with respect to the actual sensitivity and therefore any subsequent electronics will be required to adjust for the actual sensitivity of the transducer.

## TRIED, TESTED AND APPROVED...

Quality and customer satisfaction have been central to the relationships that we have developed with our metrology & measurement customers over a period of many years. We are committed to providing the highest standards of sensor technology and service levels to all our metrology & measurement customers worldwide.

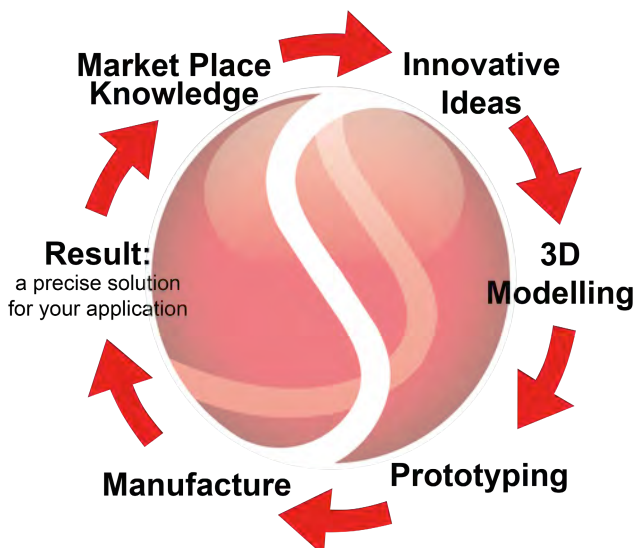

**bsi.**



## Certificate of Registration

QUALITY MANAGEMENT SYSTEM - ISO 9001:2015

This is to certify that:

Solartron Metrology Limited  
Steyning Way  
Southern Cross Industrial Estate  
Bognor Regis  
PO22 9ST  
United Kingdom

Holds Certificate Number: Q 09540

and operates a Quality Management System which complies with the requirements of ISO 9001:2015 for the following scope:

**The design, development and manufacture of position sensors (lvdt and other types) for industrial and aerospace applications. Associated signal conditioning equipment is included. Supplier of "factored" sensors and instrumentation products.**

For and on behalf of BSI:

*Andrew Launn*  
Andrew Launn, EMEA Systems Certification Director

Original Registration Date: 1990-02-26

Effective Date: 2021-03-10

Latest Revision Date: 2021-02-03

Expiry Date: 2024-03-09

Page: 1 of 1



...making excellence a habit.™

This certificate was issued electronically and remains the property of BSI and is bound by the conditions of contract. An electronic certificate can be authenticated [www.bsigroup.com](http://www.bsigroup.com). Printed copies can be validated at [www.bsigroup.com/ClientDirectory](http://www.bsigroup.com/ClientDirectory).

Information and Contact: BSI, Standards Court, Davy Avenue, Ipswich, Suffolk IP6 8PP. Tel: +44 345 080 9000  
BSI Assurance UK Limited, registered in England under number 7505321 at 399 Chiswick High Road, London W4 4AL, UK.  
A Member of the BSI Group of Companies.



# GLOBAL NETWORK

## UK (HEADQUARTERS & FACTORY)

**Email:** sales.solartronmetrology@ametek.com

**Tel:** +44 (0) 1243 833 333

**Address:** Solartron Metrology, Bognor Regis,  
West Sussex, PO22 9ST

## FRANCE

**Email:** info.solartronmetrology@ametek.com

**Tel:** +33 (0) 1 30 68 89 50

**Address:** AMETEK SAS, Solartron Metrology  
Division, Elancourt, 78990 France

## GERMANY

**Email:** vertrieb.solartron@ametek.com

**Tel:** +49 (0) 2159 9136 500

**Address:** AMETEK GmbH, Solartron Metrology  
Division, 40670 Meerbusch

## DISTRIBUTORS

Solartron Metrology has over 30 distributors worldwide, see our website for your nearest distributor, [www.solartronmetrology.com](http://www.solartronmetrology.com)

## NORTH AMERICA

**Email:** usasales.solartronmetrology@ametek.com

**Tel:** +1 800 873 5838

**Address:** Solartron Metrology, USA Central  
Sales Office, Gastonia, NC 28054

## CHINA

**Email:** china.solartronmetrology@ametek.com

**Tel:** +86 21 5763 2509

**Address:** AMETEK Commercial Enterprise  
(Shanghai) Co., Ltd, Shanghai, 200131, China

## THAILAND

**Email:** hidenao.tanaka@ametek.com

**Tel:** +66 2 012 7500

**Address:** AMETEK Thailand, Solartron Metrology  
Division, Samutprakarn, Thailand, 10540

## REAL PRECISION. REAL SOLUTIONS.

In the laboratory, on the shop floor or in the field, Solartron Metrology's products provide precise linear measurements for quality control, test and measurement and machine control.

Solartron Metrology is a world leader in the innovation, design and manufacture of precision digital and analogue dimensional LVDT gauging probes, displacement sensors, optical linear encoders and associated instrumentation.



AMETEK

Solartron Metrology pursues a policy of continuous development. Specifications in this document may therefore be changed without notice.



© Solartron Metrology 2023

